



Amendment List		Amended by	Date Incorporated
No	Date		
1			
2			
3			
4			
5			
6			
7			
8			
9			
10			
11			
12			
13			
14			
15			
16			

# ACP 33

## FLIGHT

### CONTENTS

Volume 1 .....History of Flight

Volume 2 .....Principles of Flight

Volume 3 .....Propulsion

---

**Volume 4 .....Airframes**

---

## Volume 4

# Airframes

---

Chapter 1 ..... Airframe Design - Introduction

Chapter 2 ..... Airframe Design - Structures

Chapter 3 ..... Airframe Design - Shape

Chapter 4 ..... Materials

Chapter 5 ..... Wings

Chapter 6 ..... Fuselage and Tail Units

Chapter 7 ..... Engine Installation

Chapter 8 ..... Undercarriages

Chapter 9 ..... Control

Chapter 10 ..... Auto-pilot and Related Systems

Chapter 11..... Aircraft Systems

Chapter 12 ..... The Cockpit

Instructors' Guide

---

---

## **ACKNOWLEDGEMENT**

Grateful thanks are due to Mr Ray Wilkinson of the Department of Mechanical, Aerospace and Automotive Engineering, University of Hertfordshire, who has extensively revised and re-written the text for this training manual.

---

# CHAPTER 1

## AIRFRAME DESIGN FEATURES - INTRODUCTION



**Fig 1-1** Into the 21st Century-EF 2000

### The Structure

#### **What is an Aircraft Structure?**

1. Airframe Components. A typical aircraft structure is shown in Figure 1-2. An aircraft is made up of a great many parts. This is because it is an extremely complex structure, and each part has its own specific job to do. Even if it were possible to build an aircraft in one single piece, this would not be the best thing to do. Some parts will become damaged, wear out or crack during service and we need to be able to repair or replace them. If a part begins to crack, we need to be sure that the structure will not fail completely before it is found during maintenance inspections, or the aircraft may crash.

The airframe is split into four main components:

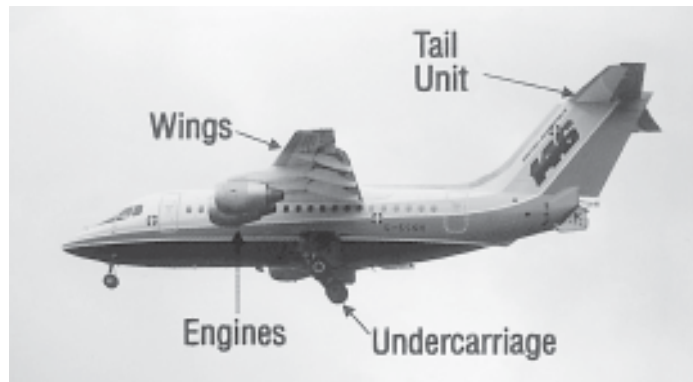
The mainplanes or wings

The fuselage or body

The tail unit (or foreplanes, for a canard-type aircraft as in Figure 1.1)

The undercarriage

**Fig 1-2** Four Main Components of an Airframe



Each of these has its own special functions to carry out, but together they form part of one and the same airframe. Before looking in detail at how they are constructed, we need to understand their main design features, and to appreciate the forces that will be acting on them when the aircraft is in flight.

**How an aircrafts wing works**

2. Wings. From your study of Principles of Flight, you will know that to fly in the Earth's atmosphere at all an aircraft must have wings designed to generate lift from the airflow over them. To take off and climb, the wings must produce more lift than the aircraft's total weight, which for an aircraft weighing perhaps hundreds of tonnes is no mean task. If the aircraft is to fly in very tight turns, the wings must produce lift equal to perhaps eight times the aircraft weight. For level flight the lift produced must equal the aircraft's weight, and for landing, where the slowest possible landing speed is required, enough lift must be produced to keep the aircraft flying at low speeds. For this it will normally have special devices added - flaps, leading-edge slats, and so on.

Thus the wings are the main component of an airframe. In fact, aircraft have been designed which consist only of a pair of wings. A more common compromise can be seen in aircraft like the Boeing B-2, F-117 and delta aircraft like Concorde. When an aircraft is moving through the air, the resistance from the air to this motion is called drag. The wings need to be made strong and stiff to resist the forces of lift and drag, which try to bend them upwards and backwards.

In most aircraft, the wings carry all or most of the fuel and also the main undercarriage; in military aircraft they often carry a substantial part of weapon loads and other external stores. All of these things will impart loads onto the wing structure.

## The Fuselage.

### **Functions of a fuselage**

3. The fuselage serves a number of functions:

It forms the body of the aircraft, housing the crew, passengers or cargo (the payload), most of the aircraft systems - hydraulic, pneumatic and electrical circuits, electronics.

It forms the main structural link between the wings and tail or foreplanes, and holds these at the correct positions and angles to the airflow to allow the aircraft to fly as it was designed to do. The loads transmitted from these items, particularly the wings and tail, try to bend and twist the fuselage, and it must resist these forces.

Engines may be installed in or attached to the fuselage, and the thrust and inertia forces generated by them can be very high.

Most modern aircraft have some form of pressurisation system in the fuselage. This is because they fly at such altitudes that the passengers and crew would find it uncomfortable or even impossible to survive. So the inside of the fuselage is pressurised to simulate a lower altitude, of around 2,400 metres (8,000 feet) for transport aircraft, and up to 7,600 metres (25,000 feet) for military aircraft (with crew oxygen). These pressure forces try to burst the fuselage like a balloon.

These many forces can all exist at once, and the fuselage needs to be strong and stiff enough to hold its shape for many flying hours.

The fuselage is often blended into the wing to reduce drag. In some aircraft it is difficult to see where the fuselage ends and the wing begins.

## The Tail Unit

### **What is a Tail Unit**

4. The tail unit normally comprises a fixed vertical fin with a movable rudder and either a fixed horizontal surface with movable elevators or an all-moving horizontal surface. There is, however, another form of control surface which is finding increasing popularity in fighter aircraft. In this layout, the horizontal tail surface is replaced by moving control surfaces at the nose of the aircraft. These surfaces are called

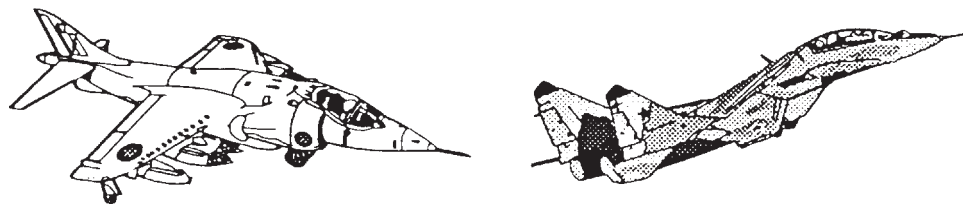
foreplanes, and this layout is known as the canard layout, from the French word for duck, which the aircraft is said to resemble.

Whichever layout is used, these surfaces provide stability and control, pitch and yaw, as described in the Principles of Flight course. There are also other ways of providing this, but initially we shall think of the tail unit as a fixed fin and tailplane, with movable control surfaces attached to them. The tail needs to be at the end of a long arm, to make it as small as possible, reducing drag and weight. For this reason it is placed at the rear of the fuselage, furthest from the aircraft centre of gravity.

Forces created by the tail are up, down, left and right, and there are usually twisting forces as well. All of these forces must be resisted and absorbed by the fuselage.

---

**Fig 1-3** Tail Units




---

### The Undercarriage

#### **Function of an undercarriage**

5. The undercarriage serves two purposes, which are equally important. The first is to support the aircraft on the ground and to allow it to move around or taxi. The second is to absorb landing shocks, allowing the aircraft to land smoothly without bouncing. It must also resist braking and side loads. The undercarriage is not needed at all in flight, and so must be as small and light as possible, and it is normally retracted into the wings or fuselage for normal flight to reduce drag.

### WEIGHT

6. It is good practice in all designs to be as economical as possible, and to keep weight as low as possible. In aircraft it is especially important, and great efforts are made at the design stage to eliminate all excess weight. The maximum weight of an aircraft is set by its design, and any extra weight taken up by the structure is not

available for payload or fuel, reducing its operating efficiency. This is made worse by the weight spiral effect, where an increase in weight in one area means that other areas need to be strengthened to take the extra loads. This increases their weight, and may mean more powerful engines or bigger wings are required. In this way, a small aircraft may become a larger one, purely by poor weight control during design.

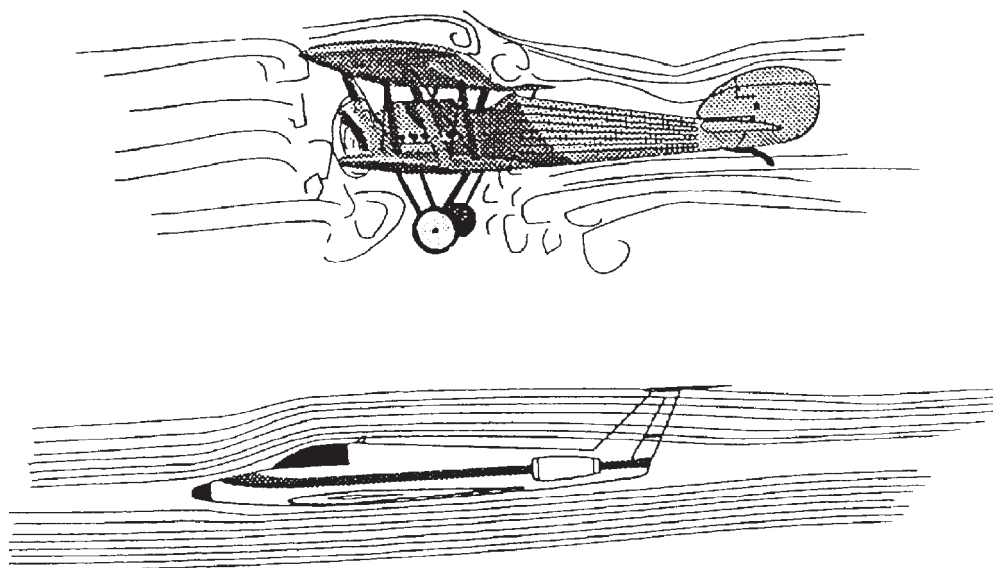
There are many ways of saving weight, but one of the most common one is to use different materials. Often these may be more expensive, but the extra cost may be justified by the improved performance.

### DRAG

7. To get the best possible performance an aircraft must be shaped so that its drag is reduced to the minimum possible. The external shape has a great influence on the design of the structure, since low drag is so important. Drag rises as the square of speed, so high-speed aircraft are critical in this area. It is not possible to design an aircraft to give the minimum drag, without taking into account structural factors. Inevitably, the final design is a compromise. The most successful aircraft are those in which the best compromises are found.

---

*Fig 1-4 Shape Affects Drag*



## AERODYNAMIC FORCES

### ***Aircraft weight and air loads***

8. As well as having to lift its own weight, including its payload (which may total as much as 350,000 kilograms for a Boeing 747), an aircraft is subject to air loads on its structure which can become very high in certain conditions. A wind with a speed of 100 knots is flowing at hurricane force, and could easily lift the roofs from houses, but houses are not shaped to cope with the forces these winds generate. Put an engine in an airframe and propel it through the air at 100 knots and we can generate enough lift to lift many tonnes, as well as giving the stability and control needed.

However, 100 knots is quite a slow speed for an aircraft, and there is always a demand for higher speeds. These higher speeds create much higher air loads, especially when the aircraft is manoeuvring or meets gusts. Even worse, the loads increase as the square of the airspeed, so increasing the airspeed to 500 knots increases the air loads by twenty five times.

Fortunately, lift increases as well as drag, and we can use this extra lift, so that fastflying aircraft can carry much higher loads. We need to make sure that the structure is able to cope with the higher loads that it will see.

9. It is important to remember that most of the loads which generate the stresses on the airframe structure come about from the effects of air pressures on the external surfaces of the airframe, and that these will vary over a wide range, depending on whether the aircraft is cruising, diving, climbing or in turbulent air, and also of course on its speed.

## CONCLUSIONS

10. To build an airframe to cope with the ever-increasing demand for higher weights and speeds, and to do this with the lightest possible structure weight, the designer must resolve many problems. A thorough understanding of the loads on an aircraft structure is needed, and we can look at the examples in later chapters to see how the designers build light yet strong and stiff structures. These structures must also be safe and reliable.

## Self Assessment Questions

***Do not mark the paper in any way - write your answers on a separate piece of paper.***

1. How many main components in an airframe?
  - a. 2
  - b. 5
  - c. 4
  - d. 3
2. What is the main component of an airframe?
  - a. The fuselage
  - b. The tail unit
  - c. The wings
  - d. The undercarriage
3. What 2 main purposes does the undercarriage serve?
4. What common way is used to save weight in the design of aircraft?

## CHAPTER 2

### AIRFRAME DESIGN FEATURES - STRUCTURES

#### Introduction

1. Any airframe basically consists of a skeleton framework with a covering to give it its aerodynamic shape. In many modern aircraft, the covering and part of the framework are made as one piece. Anyone can see the covering, or skin, but if we are to understand how a designer reduces weight but at the same time designs a strong, stiff and reliable structure we must look inside and study the skeleton underneath.

An aircraft structure is very complex, as can be seen in Figure 1-4. However, this complex structure can be broken down into groups of fairly simple components, each doing a specific task.

#### STRUTS, TIES, BEAMS AND WEBS

#### ***Structure types in aircraft***

2. The structure of most airframe components is made up of four main types of structural pieces:

#### Ties

Ties are members subject purely to tension (pulling). A tie can be a rigid member such as a tube, or simply a wire.

#### Struts

Struts are members in compression. It is much more difficult to design a strut than a tie, because a strut is liable to bend or buckle. If struts are put under compression until they fail, a long strut will always buckle, a short strut will always crack (crush) and a medium strut will either buckle or crack, or sometimes both. Hollow tubes make the best struts.

#### Beams

Beams are members carrying loads at an angle (often at right angles) to their length, and take loads in bending. The beams in an airframe include most of the most important parts of the structure, such as the main spars and stringers.

The fuselage and wings themselves are structural members, and are beams, because they resist the bending loads imposed by the weight and air loads.

### Webs

Webs are members carrying loads in shear, like tearing a piece of paper. Ribs and the skin itself are shear webs.

#### ***Other parts of an airframe***

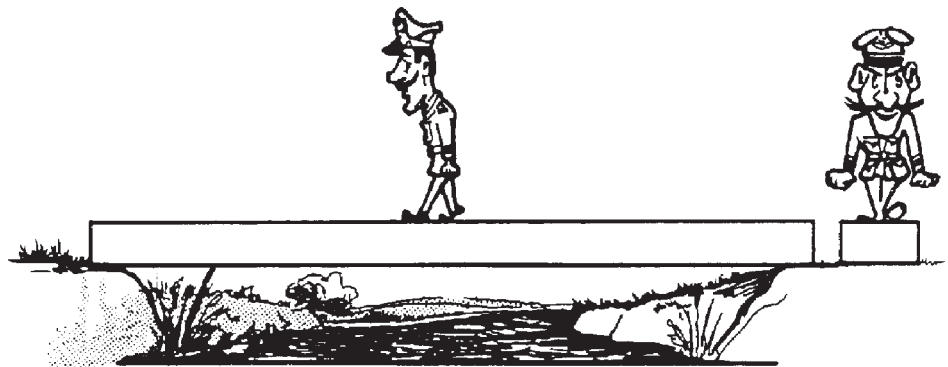
You may get the impression that each part of an airframe is either a tie or a strut or a beam or a web, but this is not so. Some items, such as wing spars, act almost entirely as one type of member, but others act as different members for different loads. For instance, the main spar near the fuselage will transmit load in bending and in shear.

3. By carefully mixing these members, and making sure that each part of each member is taking its share of the loads, the designer will achieve the greatest strength with minimum weight, and so get the best operating efficiency and maximum safety.

#### ***Reducing weight***

4. As an example, let us look at how we could reduce the weight of a solid metal beam being used as a bridge across a stream.

**Fig 2-1** *Solid-Beam Bridge-Very Heavy*



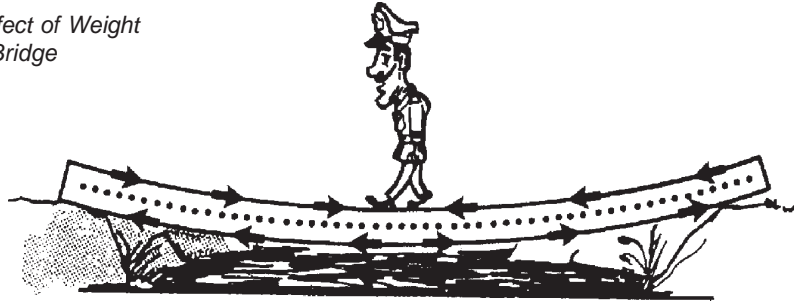
When the man walks over the solid block bridge, it bends under his weight.

The top surface is in compression.

The bottom surface is in compression.

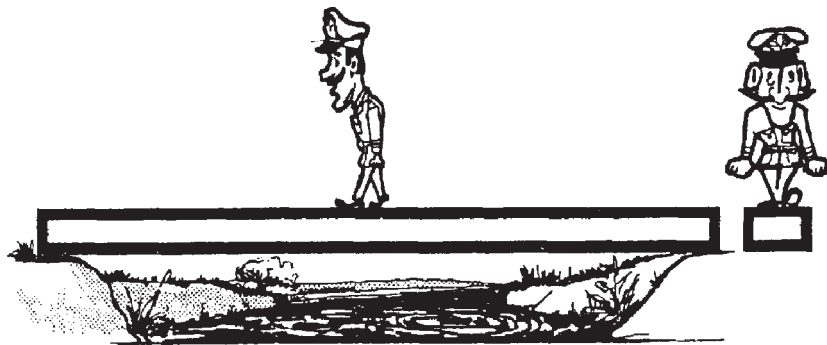
The centre is least affected.

*Fig 2-2 Effect of Weight on Solid Bridge*



We could make the bridge lighter by removing some or all of the centre. This would have very little effect on its strength, because the centre is least affected and therefore it does not carry much of the load. We must make sure that the top and bottom sections are still strong enough to carry the load.

*Fig 2-3 Hollowed-Out Bridge*

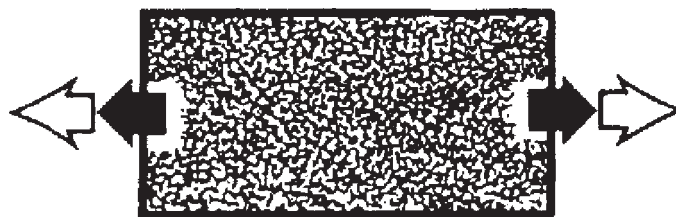


You can see that the top section is acting like a strut, and the bottom section acts like a tie.

**Tension**

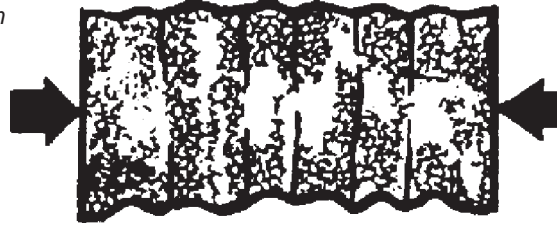
5. Now we can look at the sides of our bridge. If you take hold of a piece of paper and pull it from each end, you will see that it is quite strong in tension.

*Fig 2-4 Paper-Strong in Tension*



If you push the ends of the paper inwards, it distorts easily, because it has little resistance to compression. Because the paper is so thin, it will buckle easily.

**Fig 2-5** Paper-Weak in Compression



Now roll the paper into a cylinder and then push the ends together. It is much stronger in compression, because of its shape. So the sides of the bridge are important to support the top and bottom, preventing the bridge buckling and distorting out of shape.

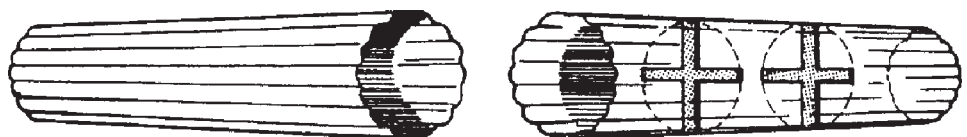
**Fig 2-6** Paper Roll-Improvement in Compression



### **Braced Structures**

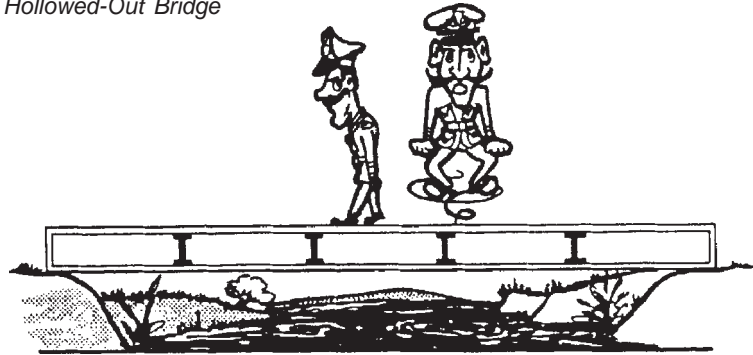
6. When our paper tube does fail, it is because the walls buckle. If we braced the inside or corrugated the walls, it would prevent them buckling, and make it even stronger. We can do this to the bridge, and use even thinner walls, provided they are properly braced.

**Fig 2-6** Corrugation and Braces-Even Better



---

**Fig 2-8** A Hollowed-Out Bridge

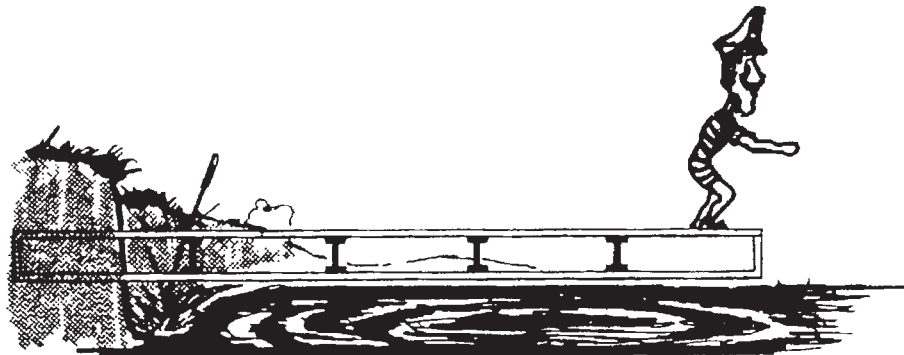


---

It is now much lighter, and looks something like a modern bridge or part of an airframe.

---

**Fig 2-9** A Diving Board



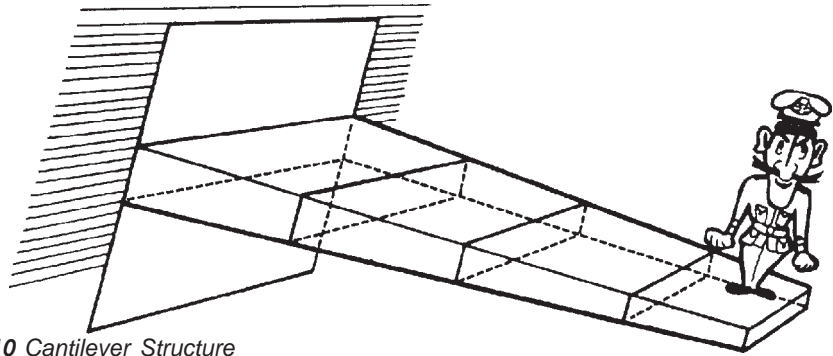
---

7. So much for a bridge supported at both ends, but what happens if the bridge can be supported at one end only? Suppose our bridge is to be used as a diving board.

It can still carry a load, but the whole of the force is taken at its supported end. Provided the outer, unsupported end is strong enough to carry the man, we can make it smaller than the supported end. The supported end needs to be strong enough to carry the weight and bending from the man plus the whole of the structure. We would want to make this bigger than our previous bridge. The strongest, lightest structure to do the job of our diving board would look like Figure 2-10. This is called a cantilever structure.

**Cantilever construction**

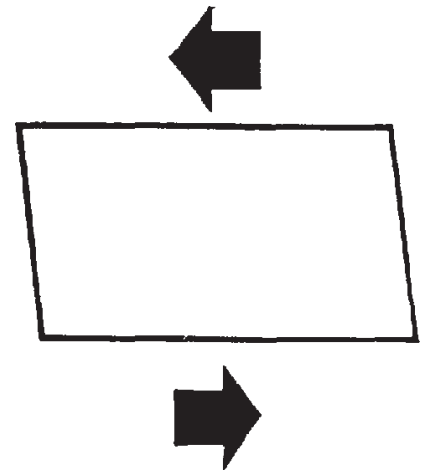
Like the supported structure, the cantilever will still bend downwards, but this time the top will be in tension and the bottom in compression.



**Fig 2-10** Cantilever Structure

The cantilever structure is widely used in aircraft, because it contains many structures which are attached at one end. The wings are just one example of this. Because they need to be much stronger and stiffer at the root (the attachment to the fuselage), they are wider and deeper there than at the tip, where loads are much less. There are many other examples of cantilever structure.

**Fig 2-11** Shear Forces



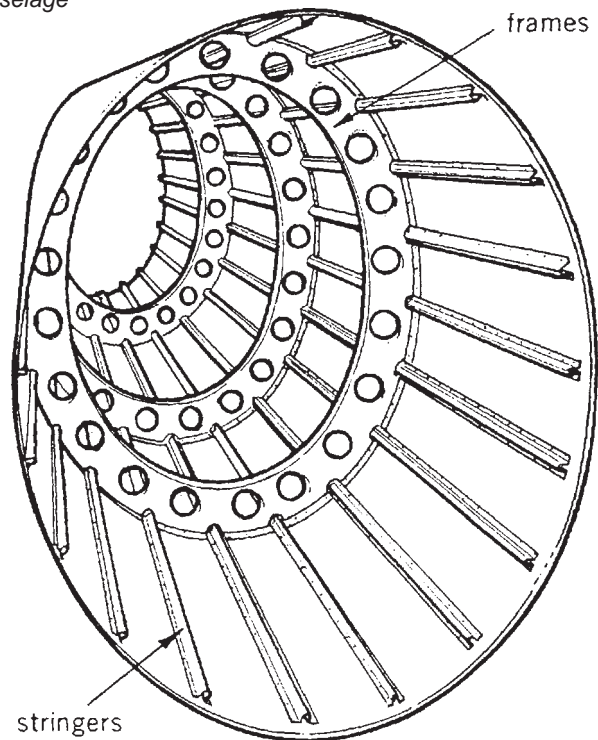
### STRESSED SKIN AND MONOCOQUE CONSTRUCTION

8. If you now take a piece of paper, hold it flat on a table or desk and try to pull it as shown in Figure 2-11, this is called shear. Paper is quite strong in shear, as are many sheet materials. This is the type of load that occurs on many parts of an aircraft, such as the skin or covering. The whole airframe can be made much stronger and lighter if the skin can be made to contribute to its strength. In light aircraft the covering is often of fabric, doped to proof it against air, weather and sunlight. The covering is required to take the pressure of air flowing over it, but makes only a small contribution to the strength.

**Stressed Skin Construction**

In faster aircraft, sheet metal, normally aluminium alloy, is used. Because of its extra strength, a large part of the load can be borne by this skin, and the underlying structure can be reduced to save weight. This is called stressed skin construction. It also has the advantage of providing a very smooth surface, because the skin is stiff enough not to sag, which is important for high-speed aircraft.

**Fig 2-12** Semi- Monocoque Fuselage

**Monocoque Construction**

It is possible to make the skin strong enough to carry all of the load, without the need for any supporting framework, a method called monocoque construction. In practice, the size of most aircraft would mean that the skin would need to be very thick to avoid buckling, and a compromise, called semi-monocoque, is usually used (Figure 2-12). In modern aircraft, it is common for the stressed skin to carry about half of the total load carried by the skin/stringer combination.

**Stringers**

The figure shows a fuselage, consisting of a series of hoops, or frames, at intervals along the skin, which give the fuselage its cross-sectional shape, connected by stringers which run the length of the fuselage. Stringers are really stiffeners to prevent the skin buckling. Semi-monocoque is an ideal form of construction for fuselages, since it leaves most of the interior free of obstruction, and is used in most aircraft.

## Self Assessment Questions

***Do not mark the paper in any way - write your answers on a separate piece of paper in the form of a sentence.***

1. How many main types of structural pieces in an airframe component?
  - a. 2
  - b. 3
  - c. 5
  - d. 4
2. What structure is widely used in aircraft design?
3. What are stringers?

## CHAPTER 3

### AIRFRAME DESIGN FEATURES - SHAPE

#### Introduction

##### **Shapes of aircraft**

1. The shape of an aircraft is extremely important, because it dictates how well an aircraft can do a particular job. For a slow-flying aircraft which needs to lift heavy loads, a large wing is needed, together with a fairly light structure. For fast jets, a much smaller wing is required, and the aircraft will be more streamlined. The structure of the aircraft will be much stronger and stiffer, to resist the high loads arising from high speed flight, and tight turns. In this chapter, we will look at how aircraft shapes are decided, and other factors which influence the design.

#### WING LOADING

##### **Aircraft Design**

2. One of the most important factors in an aircraft design is its wing loading, which is simply its weight divided by its wing area. The weight of the aircraft can vary, both with the load it is carrying and as a result of manoeuvres (flying at 4g in a turn increases an aircraft's effective weight to four times its normal weight), so its wing loading will change. A useful guide is to use the maximum take-off weight (MTOW) to calculate a "standard" wing loading. Light aircraft will normally have the lowest wing loading, and fast jets the highest, with transport aircraft in between.

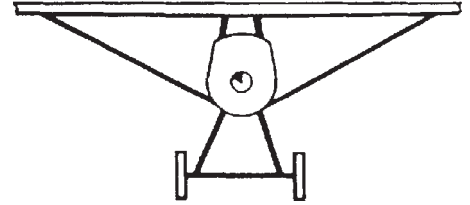
#### MONOPLANES

3. Although there are still a few biplanes around, virtually all aircraft now are monoplanes, having a single pair of wings. This provides a very stiff, strong wing, without the drag penalty of the biplane arrangement. Many light aircraft are braced monoplanes, having a diagonal bracing tie between the wing and fuselage (Figure 3-1). This allows a lighter structure in the wing, because some of the lift load is taken by the brace. The extra drag caused is acceptable at low speeds.

4. The cantilever is used for aircraft of all speeds, because it offers the lowest drag. It can be categorised as low-wing, mid-wing and high-wing, depending on where it is attached to the fuselage. Typically, low wing will be used for jet transport

---

**Fig 3-1** *Braced Monoplane*



and many light aircraft, high wing for turbo-prop transport aircraft and mid-wing for combat aircraft, but there are many exceptions.

**Aircraft Wings - Design**

5. The wings have to be strong enough and stiff enough to carry the whole weight of the aircraft, plus its aerodynamic loads, without the need for external bracing. For a Boeing 747 weighing 350 tonnes, the wing will need to be capable of resisting loads of over 1000 tonnes without failing or excess distortion. Chapter 5 shows how this can be achieved. It must also be able to cope with the highest speeds of the aircraft without deflecting too much, causing aerodynamic flutter, which can cause damage and loss of control.

6. For high speeds, a short wing span, low wing area and high wing loading are best, while for low speed a large span, high wing area and low wing loading are ideal. For landing, it is possible to change the wing area and wing section to some extent by adding flaps at the trailing edge. This makes the wing structure more complicated. High speeds also demand retractable undercarriages and low frontal area. More thrust is required, so turbo-fan or turbo-jet engines will be needed, in preference to the turbo-prop engines most efficient for lower speeds. At very high speeds, the cross-section of the fuselage and wing are very carefully designed, using the area rule to achieve low drag, leading to some very complex aircraft shapes (Figure 3-2).

---

**Fig 3-2** *Area Rule-  
'Coke-Bottle'*

*Fuselage Photo:  
R Wilkinson*



7. Strength/Weight Ratio. Higher speeds are more easily achieved by smaller wings, so these have to be made stiffer and stronger to carry the higher wing loads and inevitably higher landing speeds. This all tends to increase weight, which we try to avoid. Weight per square metre of wing area has certainly increased, but the designer makes sure that the material is put to the best possible use, and uses the strongest and lightest materials. In this way, the strength-to-weight ratio of the structure is improved. Modern materials can also play a part in allowing higher stresses to be used, but may be much more expensive.

SWEEP BACK, SWING WINGS AND DELTA WINGS

**Problems of speed**

8. For aircraft flying at or near supersonic speeds, the way in which air flows over the aircraft is very different, and the designer has a new set of problems to face. An aircraft flying quite slowly through the air generates pressure waves, which move at the speed of sound, and 'warn' the oncoming air that the aircraft is approaching. At speeds near the speed of sound, these waves can no longer arrive early enough, and a shock wave forms on the leading parts of the aircraft. The air behind this shock wave becomes turbulent, causing loss of lift, increased drag, changes in trim and buffeting of controls. Designers have reduced the effects of these problems with better designs, particularly swept-back wings. But these features cause other problems, because they are more difficult and expensive to build (Figure 3-3).

9. Once flying above the speed of sound, the airflow is steady again, although quite different to subsonic conditions. The curved shapes that give good streamlining at lower speeds are no longer the most efficient, and straight lines and sharp edges are preferable.

**Fig 3-3** Swept-Back Wings (E3-A Sentry)

Photo: R Wilkinson



The plan form of wings becomes more important than their section, and low aspect ratio and sharper sweepback may be necessary. The reduced aspect ratio (see paragraph 13) makes wings easier to design, but the loads are very high, and the structure must be strong and rigid.

### **Swept Back Wings**

10. The main disadvantage of swept-back wings is that they produce much less lift than an unswept wing of the same area and aspect ratio (see paragraph 14). This means that when the aircraft is flying slowly, for instance during landings, a larger angle of attack is required to provide enough lift. This can cause problems in undercarriages and in pilot visibility. We could just use a larger wing - this would improve the turn performance for a fighter, but would also reduce its top speed because of higher drag and higher weight.

11. If we could change the amount of sweepback in flight, that would go a long way towards getting the best in both situations. This has been done on many highspeed military aircraft - in the forward (unswept) position it gives a straight wing of high aspect ratio for good low-speed performance, allowing tight turns at low speeds and also making flaps more effective for take-off and landing. In the swept position it is highly suited to high-speed flight .



**Fig 3-4** Variable Sweep-Back (Tornado)

### **Delta Wings**

12. Another option for aircraft which need to fly at high speeds but also need to be able to turn tightly at all speeds is the delta wing. This has the advantage of high sweepback, but the trailing edge is more suited to fitting effective flaps. Because of the aerodynamics of delta wings, they are capable of producing lift at much higher angles of attack than other wing shapes, and so can be used on highly agile fighter aircraft. Delta wings, which went out of fashion in the 1970s and 1980s, are becoming

more common on these aircraft, and many examples can be seen, often in conjunction with canard foreplanes for control (Figure 3-5).



**Fig 3-5** Delta Wing with Canard Foreplane (EF 2000)

### ASPECT RATIO

**Ratio of wing span to its average chord**

13. The aspect ratio of an aircraft's wing is an important design feature, and is simply the ratio of the wing span to its average chord. This is not always simple to calculate if a wing shape is complex, so another way of defining it is:

$$\text{aspect ratio} = \frac{\text{span}^2}{\text{area}}$$

So if a wing has an area of 80 square metres and a span of 20 metres the aspect ratio is  $(20^2/80 = 5)$ . It is usual to use the projected area to calculate the aspect ratio, that is, to include that part of the wing which is inside the fuselage. High performance sailplanes have aspect ratios in the region of 25 to 30, and fighters somewhere around 5 to 10. High aspect ratio reduces the induced drag caused by air flowing around the wing tips, and is ideal where long slow flights are required. The drawback is that long, thin wings need to be heavier, and are very flexible.

### THE BEST COMPROMISE

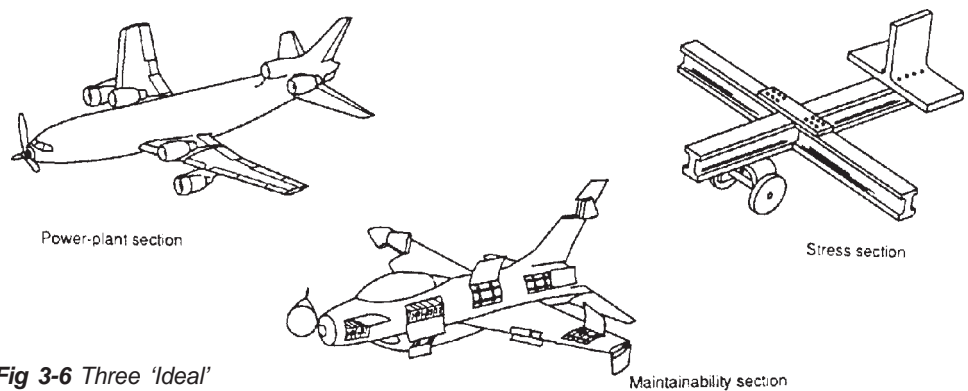
14. All aircraft designs are a compromise, because it is not possible to get the best possible design in one respect without conflicting with another. The

aerodynamicist may want a smooth, thin wing, but the structural designer wants the wing to be thick, to make it stiffer. The weights engineer would prefer there to be no wing at all, since no payload can be carried in it. Figure 3-6 shows how an aircraft might look if it were designed by each of the various specialists! Inevitably, then, the best aircraft is the one that has found the best set of compromises.

**Factors in the design of aircraft**

Designing an aircraft is an iterative process - it goes around a number of cycles before the final design is reached. There are many other factors which affect how the aircraft will look - materials availability, available technology, company standard practices and the operating requirements of the user all influence the final design.

15. The designer has many problems in selecting the right shape for his aircraft, and must constantly seek compromises to get the best performance in all the different parts of the aircraft flight. Once the overall shape of the aircraft has been finalised, the problems of making the airframe, in materials which provide the best strength/ weight ratio and stiffness must be tackled. This we will do in the next chapter.



**Fig 3-6** Three 'Ideal' Aircraft

## Self Assessment Questions

***Do not mark the paper in any way - write your answers on a separate piece of paper in the form of a sentence.***

1. What is one of the most important factors in an aircraft design?
2. How can higher speeds be achieved in the design of aircraft?
3. How do we define the Aspect ratio of an aircraft's wing?

# CHAPTER 4

## MATERIALS

### Introduction

#### ***Types of materials used in aircrafts***

1. In previous chapters we have stressed that the materials used in structural areas of airframe construction must have a high ratio of strength to weight. The following groups of materials come into this category, and are used for the main structural parts:

Aluminium and magnesium alloys (Light alloys)

Steels

Titanium and titanium alloys

Plastics and composites

2. It is difficult to say exactly how different materials compare with each other, because there are so many different factors to consider. For example, some resist tension (stretching) better than others; some resist compression better, and so on. Even different types of aluminium alloys are preferred by different types of loads. But we can get an idea of how different materials compare by considering their strength-to-weight ratio (SWR).

3. There are other things to consider apart from the SWR:

A material must also be consistent and predictable in its properties, so that we know what behaviour to expect from it.

It should be homogeneous, i.e having the same properties throughout, although the way a particular material is processed may upset this. If it does, it must do so in a predictable way, and leave the material in a useful state.

It must not suffer badly from corrosion or other deterioration caused by exposure to the weather, sea water or any chemicals that it comes into contact with. In particular, subjecting some materials to high loads and corrosive fluids can cause stress-corrosion cracking.

It should be non-inflammable (magnesium burns fiercely when exposed to high temperatures such as a fuel fire, but this does not usually cause a problem).

It should be readily available and at reasonable cost, and should be easy to work with using standard processes.

It should not suffer badly from fatigue, or must be used in parts where this does not cause a problem (see paragraph 18).

### ALUMINIUM AND MAGNESIUM ALLOYS

Pure aluminium and pure magnesium are completely unsuitable as structural materials for airframe, but when alloyed (chemically mixed) with each other or with other metals, they form the most widely-used group of airframe materials. These alloying metals include zinc, copper, manganese, silicon and lithium. There are very many different variations, running into dozens, each having different properties and so suited to different uses. Magnesium alloys are very prone to attack by sea water, and their use in carrier-based aircraft is avoided. Pure aluminium is very resistant to corrosion, and is often plated onto its alloys to form a protective layer. Alloy treated like this is known as Al-clad Aluminium-lithium alloys are superior to Al-zinc and Al-copper alloys in many respects, but cost around three times as much, so their use is limited.

An interesting property which aluminium shares with titanium is that it can be superplastically formed (SPF). When the material is heated to a certain temperature, but below its melting point, it becomes extremely pliable, like rubber. It can then be inflated to fill a mould and take its shape exactly. This can be used to make extremely complicated shapes cheaply and with minimum weight, although the high initial cost of tooling means it is limited to fairly large production runs.

#### 5. Advantages:

High strength/weight ratios.

A wide range of different alloys, to suit a range of different uses.

Light, so greater bulk for same weight means they can be used in greater

thicknesses than heavier materials, and thus are less prone to local buckling; this applies to magnesium alloys even more than aluminium alloys.

Available in many standard forms - sheet, plate, tube, bar, extrusions.

Easy to work after simple heat treatment.

Can be super-plastically formed.

Reasonable electrical and magnetic screening properties.

Disadvantages:

Subject to corrosion, so need protective finishes.

STEEL AND ITS ALLOYS

6. Steel is made by alloying pure iron with a wide range of other materials. This gives the possibility of producing a wide range of properties. Steels will always contain carbon, and may contain one or more of the following: chromium, nickel and titanium. Steels can be produced with a wide range of properties, ranging from extremely hard to very ductile (able to be bent and stretched). However, they all share one property, and that is that steel is heavy. Steel finds most usage where its strength can be used to best advantage, for instance where space is limited, or where its hardness and toughness are needed. The most common use is in bolts and other fasteners. It has one more advantage - it performs much better at higher temperature than most other materials except titanium, and is used for Concorde wing skins, and inside engines.

7. Advantages:

Cheap and readily available.

Consistent strength

Wide range of properties available by suitable choice of alloy and heat treatment.

High strength useful where space is limited.

Some stainless steels are highly resistant to corrosion.

High-tensile steels have high SWR.

Hard surface is resistant to wear.

Suitable for use at higher temperatures than light alloys, but not as good as titanium alloys.

Easily joined by welding.

Very good electrical and magnetic screening.

Disadvantages:

Poor SWR except high tensile alloys.

Heavy, so care must be taken not to use very thin sections, or buckling will result.

TITANIUM AND ITS ALLOYS

8. Titanium has only recently become widely available, so it is quite expensive. Its properties are very similar to steel, but at high temperatures it is far superior in strength. It is widely used in jet pipes, compressor blades and other components which are subject to high temperatures. Like aluminium alloys, titanium can be superplastically formed, allowing very strong and light items, such as pressure vessels, to be made. Titanium has another related property, that of diffusion bonding. At a precise temperature, two pieces of titanium pressed together will fuse and become a single piece. When combined with SPF, this allows even greater flexibility of design.

9. Advantages:

High strength/weight ratio.

Maintains its strength at high temperatures.

Higher melting point and lower thermal expansion than other materials.

Can be super-plastically formed and diffusion bonded.

Disadvantages:

Expensive.

Can be difficult to work, especially machining.

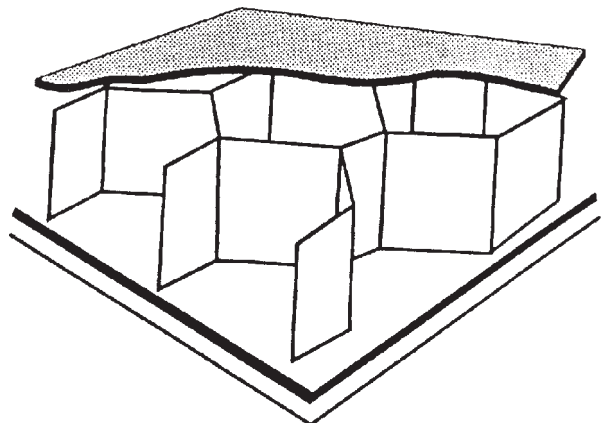
Poor electrical and magnetic screening.

A very hard scale forms on the surface at high temperatures.

### PLASTICS AND COMPOSITES

10. Pure plastics have little structural use, although it is increasing. However, widespread use is being made of composite structures in aircraft, that is, fibres of materials such as glass, carbon or Kevlar (a trade name for aramid fibre) inside a thermosetting resin such as epoxy. Often these materials are made into boards, or composite panels, which consist of a sandwich of, for example, carbon-fibre/ Kevlarhoneycomb/ carbon-fibre (see Figure 4-1). This makes a panel of limited strength, but extremely light, giving a strength/weight ratio far higher than a metal panel. They are often used for making galleys and bulkheads inside aircraft passenger compartments, but are increasingly used for aircraft structures. Composites are not exclusively plastics, and aluminium skins or honeycomb cores are commonly used, either together or with plastics. The latest generation of fighter aircraft now emerging have up to 30% of the airframe structure made of composite materials, and the Lear Fan 2100 business aircraft has a structure which consists of 77% composite materials.

**Fig 4-1** Honeycomb Composite Panel



11. Some composites can be quite difficult to repair safely. Kevlar, for instance, absorbs water if damaged, which can make it difficult to repair effectively. In all cases, very careful repairs are needed, often requiring heater mats to help the resins to cure. It is often easier to replace a damaged item, returning it to the factory or repair facility. In some cases, this is not convenient, for instance a battle-damaged aircraft needing to be returned to service as soon as possible. In any event, this method usually means that the user needs more spares, which means higher costs.

12. Another problem with the increasing use of composites, in leading edges for example, is that they do not provide electrical or magnetic shielding for cables. If the aircraft is operating close to strong electromagnetic fields, for instance on the deck of a ship, if its own radar is close by, or if a nuclear explosion occurs even many miles away, strong electric currents can be induced in the aircraft's electrical system, which may cause it to fail. If the aircraft structure cannot provide enough protection, extra shielding is needed, which adds weight, cost and complexity.

13. Advantages:

Very high strength/weight ratio and low weight.

Non-corrodible (but see paragraph 15).

easily available in a wide range of forms.

Can make complex shapes easily.

Low resistance to radar and radio signals is ideal for radomes and antenna covers.

Disadvantages:

Need special manufacturing and repair methods.

Strength and stiffness not the same in all directions.

Poor electrical screening.

Corrosive to normal metals, because of galvanic action.

## FATIGUE

14. Fatigue is a material's tendency to break under a high number of relative stresses, such as take-offs and landings or under vibration. Next to human factors, it is the chief cause of aircraft accidents. Some materials, although not as good as others in terms of strength/weight ratio, are superior under fatigue, and are extensively used for this reason.

15. To guard against such failures, aircraft life is often quoted in flying hours. For example an RAF training aircraft has a life of 5,000 flying hours and Concorde 45,000 hours (A service trainer is expected to suffer much more severe treatment than an airliner!). Fatigue meters are fitted to most RAF aircraft and these record the number of times a particular load is reached when flying the aircraft. The manufacturer carries out a long series of fatigue tests on an airframe, to find out when problems are likely to happen. By comparing the information recorded by the fatigue meter with the manufacturer's tests, remaining airframe life can be constantly monitored.

## Self Assessment Questions

***Do not mark the paper in any way - write your answers on a separate piece of paper.***

1. Give 4 materials used in aircraft design
2. How can you measure airframe life?

## CHAPTER 5

### WINGS

#### Introduction

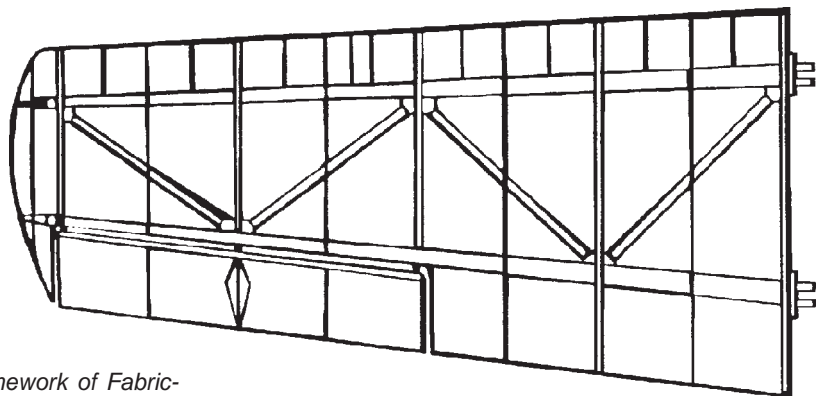
##### *Parts of a Wing*

1. As you have already seen, different sizes and types of aircraft need different construction. This applies to the mainplanes, or wings, as much as to any other part. Each wing is basically made up of two parts - the internal structure, such as spars and ribs, and the skin, which can be of fabric, metal or composites, although this distinction may not be very apparent in modern fast jets or large transport aircraft.

#### FABRIC-COVERED WINGS

2. Figure 5-1 shows a typical framework of a fabric-covered cantilever monoplane. The main structural members, as for most aircraft wings, are the front and rear spar, which are attached to each other by a series of ribs. Ribs give the wing its section, and transfer loads from the covering into the spars. Attached to the front spar is the leading edge section, in this case made up of nose ribs and the leading edge itself. The trailing edge section is similar, but of a different shape, and contains the ailerons and flaps. Although the fabric covering takes little load, it does strengthen and stiffen the structure a little, especially in torsion (twisting).

The compression ribs are the main structural ribs, and the camber ribs help to support the fabric to keep a good wing section along the whole wing.



**Fig 5-1** Framework of Fabric-Covered Cantilever Monoplane

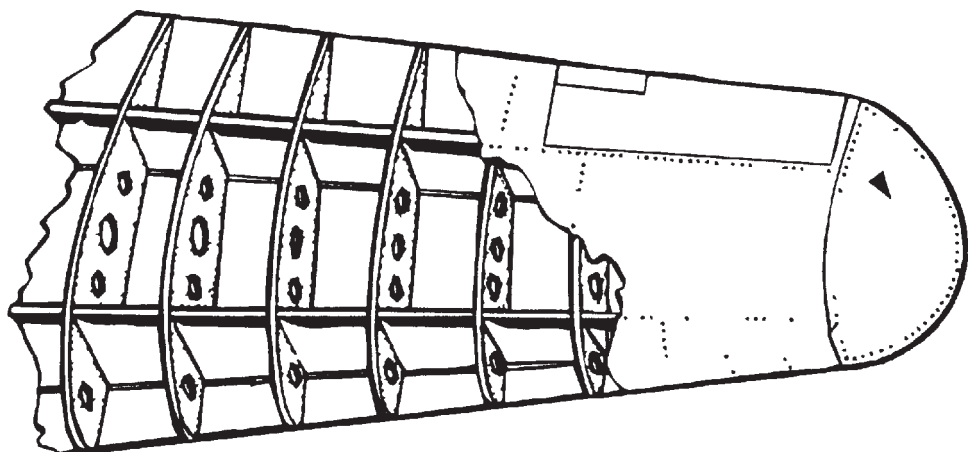
Close to the leading edge, where the section curves most, extra nose ribs are added to make sure this important part of the wings is not upset by sagging of the covering fabric.

### STRESSED-SKIN WINGS

3. You will remember from Chapter 1 that air loads increase as a the square of the speed increase. For instance at 400 knots the air loads are four times as great as the 200 knots achieved by the fastest of light aircraft. Fabric covering cannot meet these loads and so a heavier and more rigid skin must be used. Chapter 4 described how aluminium alloys are most often used for this. It gives a smoother finish and more contour to the shape than fabric covering, but if it is very thin it gives little extra strength. If the skin is thicker, it can share the loads taken by the structure underneath, which can then be made lighter. Almost all aircraft have their structure made entirely in metal, or a mixture of metal and composite materials.

The two main spars are still the main strength members, but a large contribution to the strength is made by the skin.

The whole is normally in metal construction, although the wing tip, ailerons and leading edge may be of composites. To reduce weight the ribs may have large lightening holes, with flanged edges to keep the required stiffness.

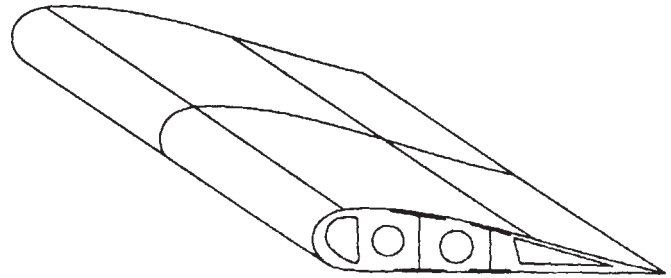


*Fig 5-2 Stressed-Skin Wing Construction*

The skin may be fixed to the internal structure by rivets, as shown on the diagram, or by bonding (gluing), using special adhesives.

The volume between the front and rear spars is often used for storing fuel, and holes in the ribs allow the fuel to flow inside this space.

**Fig 5-3** More Stressed-Skin Wing Construction



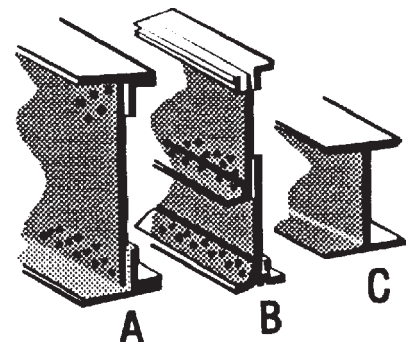
The leading- and trailing-edge sections are used for carrying electrical cables, control wires and other items along the wing.

4. This type of construction is called stressed skin (Figures 5-2 and 5-3, and it allows thin cantilever wings to be produced which are strong enough to resist the tension, compression and twisting loads caused by high speeds. Stressed skin construction is the only option for aircraft of medium to high speeds.

5. Spar Design. An ideal spar is given depth so it may resist the bending forces imposed on it. An example of this is an ordinary ruler, which will flex easily when loaded on its top or bottom surfaces, but is very stiff when a load is applied to the edge. Three typical spar sections are shown in Figure 5-4.

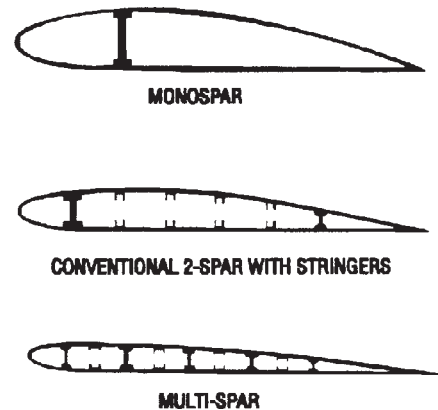
In examples A and B of Figure 5-4, the flanges could be made as part of the skin, if the skin is machined from a thicker material. In some wings, for instance the Airbus series of aircraft, the flange and part of the spar are machined as part of the skin.

**Fig 5-4** Typical Sections



But if a thin wing is needed for high-speed flight, it may not be possible to get a deep enough spar. To make the wing strong enough, more than one spar will be used. Using two spars is quite usual on many aircraft. Very high speed aircraft, with extremely thin wings, may use a multi-spar layout (Figure 5-5).

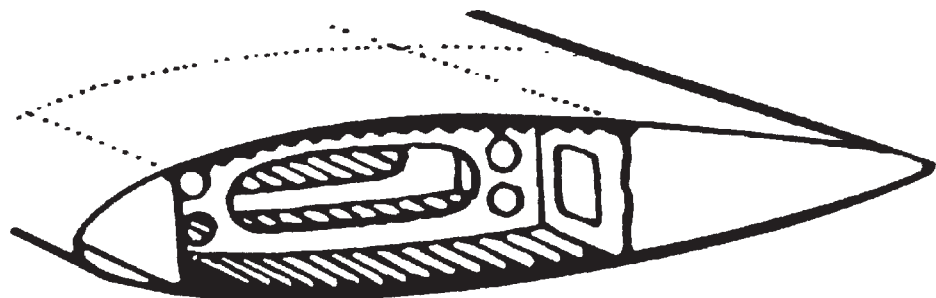
**Fig 5-5** Various Types of Wing-Spar Layouts



**Torsion box Construction**

6. Most modern aircraft use two main spars, with stressed skin between them, to form a torsion box construction. This can be seen in Figure 5-6. The leading and trailing edge sections are then added in a lighter construction, often composites, and carry very little of the loads applied to the wing. The major advantage of this is that the space within the torsion box is an ideal space to store fuel. The whole volume is sealed using special compounds to prevent leakage, and may be divided up into several large tanks, so that the fuel may be moved around as required to balance the aircraft or reduce loads in flight. The skin must be stiffened to prevent buckling, and stringers will be bonded or rivetted to them, or integrally machined, as described below.

**Fig 5-6** Torsion Box Construction



## MACHINED SKIN

### **A Billet**

7. As an alternative to making stressed skins by fastening stringers to the skin (fabricated), the skin, stringers and spar flanges can all be machined from a single piece of alloy, called a billet. This billet may be many metres long, since it is possible to make the skin for one wing in a single piece. The billet is much thicker and heavier than the final machining, with up to 90% of it being removed during machining. Although this is very expensive, in both material and machining cost, the final result is a lighter and stronger skin than a fabricated one.

### Advantages include:

Rivetting is not required, so a smoother surface is achieved.

Lighter structure with more even loading than a fabricated one.

Computer-controlled machining means mistakes or faults are less likely, and more easily detected.

Easy inspection during manufacture and in service.

No maintenance required.

Easy sealing of fuel spaces.

### Disadvantages:

High cost, particularly setting up tooling.

For combat aircraft, battle damage repair can be more difficult.

Careful design needed to maintain fail safety by limiting spreading of fatigue cracking.

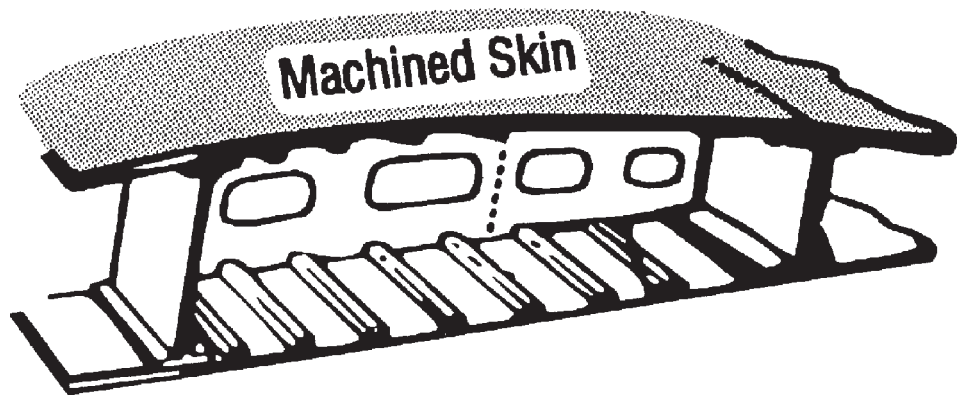
### **Delta and swept wing aircraft**

8. Because they are very different in shape to other types of wing, delta and heavily swept wings have different construction to other wings. Delta wings have a very high chord at the wing root, and so thickness for structural stiffness is not a problem. Swept wings may have to house the undercarriage when it is retracted, and the sweep means that it must be located near to the trailing edge. A solution to this is to add another short spar, and to increase the chord of the wing at the root.

This then gives enough depth in the wing to fit the retracted undercarriage, and provides a strong point for the undercarriage mounting.

---

*Fig 5-7 Delta Wing  
Construction*



## Self Assessment Questions

***Do not mark the paper in any way - write your answers on a separate piece of paper.***

1. Name the 2 parts of a Wing.
2. What is an alternative to making stressed skin by fastening stringers to the skin.

# CHAPTER 6

## FUSELAGES AND TAIL UNITS

### ***Types of construction***

1. Similar types of structure to that used in the construction of wings can be used for fuselages and tail units or foreplanes, except that fuselages are usually of the semi-monocoque type, i.e. the skin is a stressed part of the structure, and takes a share of the loads with much-reduced internal structure. Semi-monocoque construction is particularly useful for fuselages since it leaves a large proportion of the inside free to accommodate crew, passengers and cargo. In addition, the crew and passenger sections of fuselages for aircraft flying at high altitude are pressurised, i.e. the pressure inside is greater than the air pressure outside. This means that the sections must not only be airtight, but capable of withstanding the pressure, so that they will not burst. This pressure difference is typically up to 5600 kilogrammes force per square metre (that is a force equal to the weight of six cars for every square metre of fuselage skin. This is easier to achieve in semi-monocoque construction.

### ***Purpose of fuselage***

2. Remember, too, that in addition to being the body of the aircraft the fuselage:

Is the interconnecting link between the other main structural units - the wings are attached to it and convey their loads to it at the wing roots.

Has the undercarriage loads transmitted to it.

Must carry both the air loads and the weight of the tail unit and/or foreplanes.

Often carries the engine(s) in the nose or at the tail, and these exert considerable weight, thrusts and torques (twisting forces) on it.

Carries the major part of the aircraft systems - hydraulics, electronics, radar and, in the case of military aircraft, often carries some or all of the weapon load.

There are three distinct parts of the fuselage: (see Figure 6-1)

The nose section.

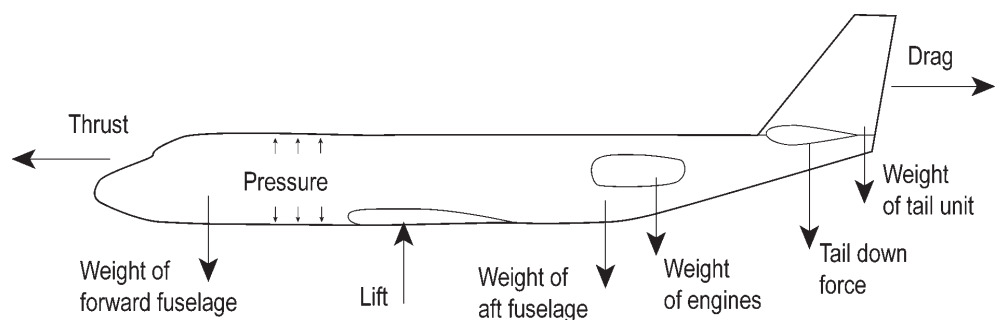
The centre section.

The aft or rear section.

**Use of the 3 Sections of a fuselage**

4. The three sections will carry different loads in accordance with the task the aircraft is required to do, but in all types the centre section needs to be large and strong. In flight, the whole aircraft will be supported by lift from the wings, transmitted through the centre of the fuselage to carry all of the other parts. In transport aircraft, the majority of the fuselage is tubular.

**Fig 6-1** Loads on a Fuselage

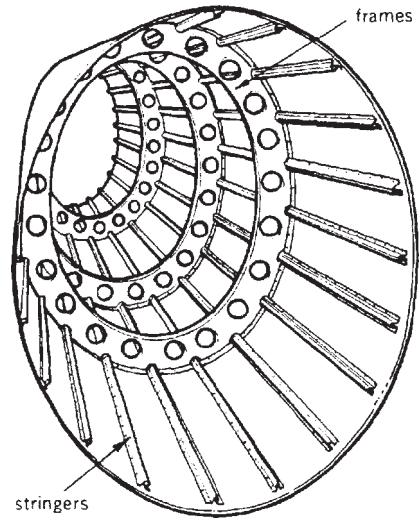


This is a convenient shape for carrying cargo or passengers, and makes it possible to stretch the aircraft (make the fuselage longer to increase its carrying capacity) by inserting extra pieces or plugs without a major re-design of the fuselage. This results in mainly cylindrical fuselages, with tapered nose and tail sections. Combat aircraft are often quite different, and the shape of the fuselage can be quite complex, because of the special task it does.

### STRESSED-SKIN FUSELAGE

5. As in wing construction described in the previous chapter, fuselage construction is usually of stressed-skin type, where the skin itself takes much of the load. The semi-monocoque construction, which is virtually standard in all but the lightest of aircraft, consists of a stressed skin, with added stringers to prevent buckling, attached to hoop-shaped frames, which give the fuselage its shape and allow it to resist the bending loads from the tail. The frames protrude into the fuselage interior by about 100 - 150 mm, leaving the rest of the fuselage clear for payload (Figure 6-2.). The designer will try to find the best compromise of skin strength (and weight) and frame and stringer strength, with the skin usually taking about half of the loads.

**Fig 6-2 Stressed-Skin Fuselage**

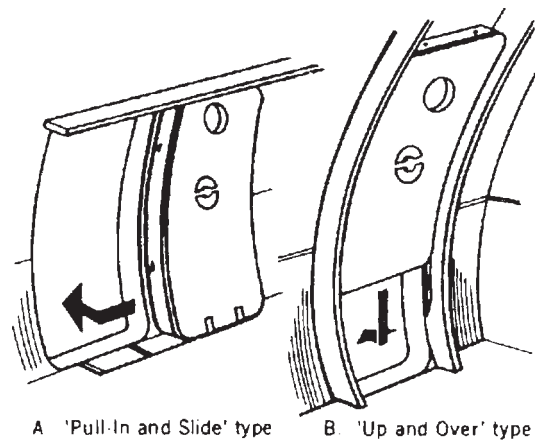


At the nose and tail, double curvature, like the surface of an egg, makes the skin even stiffer. A floor, consisting of a number of beams across the inside of the fuselage and covered in sheet alloy or composite panels, leaves a flat surface for walking on and fitting seats, and leaves a space for luggage and the many aircraft systems.

**Bulkheads - design**

6. Pressure bulkheads are fitted in the nose and close to the tail of most aircraft. They are flat discs, like a drum skin, or curved, like a breakfast bowl, and their job is to withstand the loads imposed by pressurisation of the fuselage. Cutouts need to be made in all fuselages to allow for doors and windows. This causes structural problems, because the fuselage needs to be strengthened around them. It is important to make sure that loads can be routed around these cutouts, and spread evenly into surrounding skin and structure.

**Fig 6-3 Pressure Cabin Doors**



The ideal shape for a cutout in a fuselage is an ellipse, and many aircraft have windows this shape. This is not very practical for doors, though, and the more usual shape is a rectangular door with rounded corners (Figure 6-3).

7. In paragraph 4, we saw that combat aircraft fuselages can be quite different from other aircraft. The pressurised space is usually smaller, containing just the cockpit and perhaps an electronics bay, and pressures are much lower, because the pilot also uses an oxygen mask. The fuselage may have a strong beam, called the, running fore and aft, and many of the major parts, like the engines, cannon and undercarriage, could be attached to it.

#### TAIL UNITS AND FOREPLANES

##### ***Tailplanes***

8. Tailplanes on light aircraft may be built in a similar way to a fabric-covered wing. Stressed-skin tail units are usually similar in construction to stressed-skin wings, but they are smaller, and usually have a different section, because they are not required to produce lift in normal flight. On large aircraft, the fin may contain fuel - not only does this increase the fuel capacity, but it also allows for trimming of the aircraft by transfer of weight rather than by deflecting aerodynamic control surface, and so reduces drag.

##### ***Foreplanes***

Foreplanes are of similar construction to tailplanes, but are generally smaller in size. They are almost always all-flying, that is, the entire foreplane moves to provide control movements.

##### ***Rudders***

Rudders and elevators are often made of composite materials, and sometimes even the whole tailplane is made in this way. Because of their smaller size, foreplanes lend themselves to this kind of construction (Figure 6-4 see over).



**Fig 6-4** Harrier Fin Construction

Photo: R Wilkinson

## Self Assessment Questions

***Do not mark the paper  
in any way - write your  
answers on a separate  
piece of paper.***

1. What are the 3 distinct parts of a fuselage?

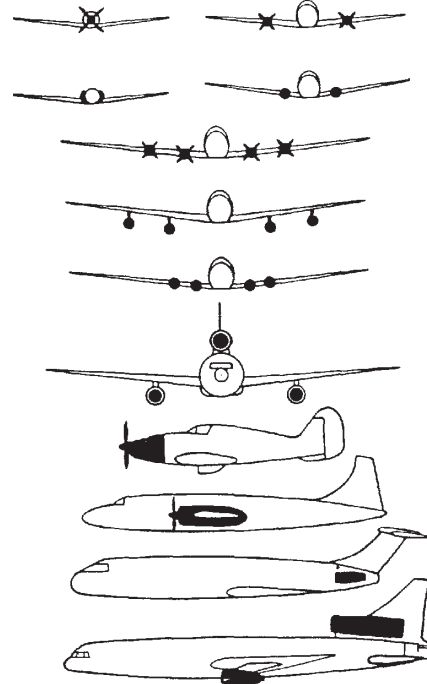
# CHAPTER 7

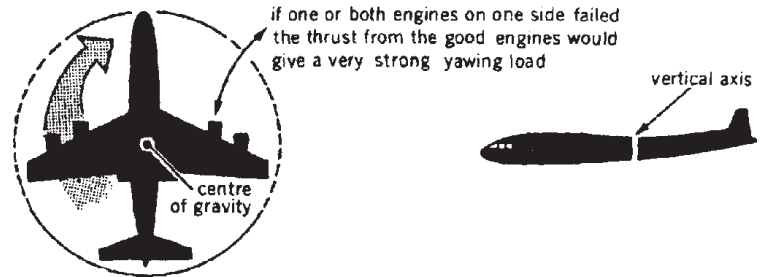
## ENGINE INSTALLATION

**Types of engines**

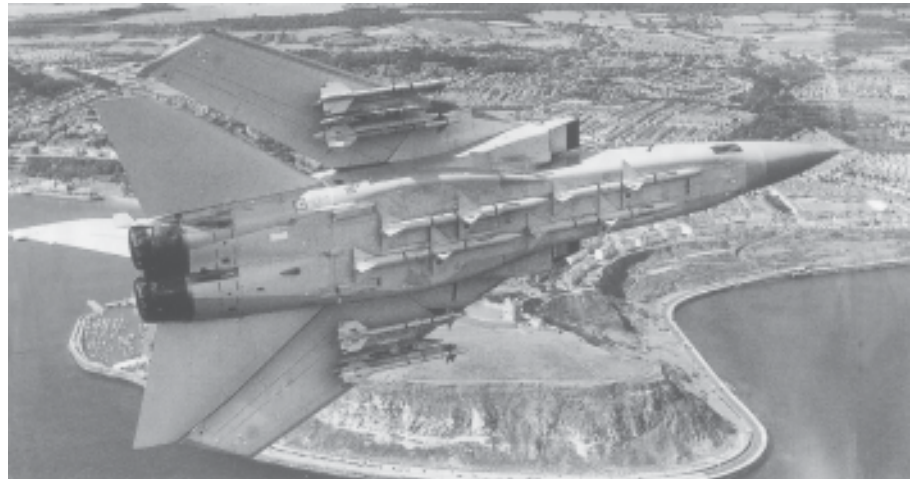
1. The designer must, of course, decide what type of engine or engines will be needed to get the specified performance from the aircraft, and then he must place them in the airframe in the best possible position. He can then strengthen the airframe components which have to carry the known or estimated engine weights and design the engine mountings , allowing for ease of installation, maintenance and removal. When placing the engines he must also consider where fuel can be carried, since the amount and weight of the fuel is considerable and depends largely on the engines chosen.
2. If only one piston engine/propeller combination or turboprop engine is fitted it will normally be in the nose of the fuselage. If a single jet engine is used it would also normally be in the fuselage, but further back, near the centre of gravity.
3. If there are two or more engines there are a variety of positions to be considered, as shown in Figure 7-1.

**Fig 7-1** Engine Positions



**Fig 7-2** Directional Stability**Twin or Four-engine aircraft**

4. If, in a twin- or four-engine aircraft, the engines are placed far out on the wing, and an engine fails, the thrust from the remaining engines or engines causes the aircraft to yaw strongly. This needs a large rudder, capable of large deflections, to allow the aircraft to be kept in straight flight (Figure 7-2). So it is desirable to place the engines as near to the aircraft centre line as possible. In the Tornado, the engines are placed side by side, as close as possible to the centre line (Figure 7-3). Another arrangement is to put engines in pods on the rear fuselage (Figure 7-4).

**Fig 7-3** Engines Close to Aircraft Centre-Line**Fig 7-4** Engine Pods on Rear Fuselage

**Prop-fan engine**

Another type of installation that is being developed is the prop-fan engine, which is a hybrid between a turbo-fan engine and a turbo-prop. It has an un-shrouded fan, which looks a little like a propeller.

5. Twin- or multi-engined propeller-driven aircraft to have their engines spaced out along the wing because there must be clearance between the propeller tips and the fuselage. The closer they are, the more noise is generated inside the fuselage, and the further away they are, the more the aircraft yaws if an engine fails. Once again, it is up to the designer to find the best compromise.

The disadvantages of having to place engines on the wings are:

Maximum yaw if an engine or engine(s) fail.

The space taken by the engines and their streamlining pods neutralises some of the lifting area of the wing, and calls for an increased span.

The wing must be insulated against engine heat.

---

**Fig 7-5** Engines Mounted on Wings



---

6. Some of these disadvantages are eliminated by using underslung pods, seen on many transport aircraft. The advantages are:

The airflow over the wing is not disturbed.

A thin section suitable for high speeds can be used.

A shorter span can be used.

More of the space in the wing can be used to hold fuel.

No heat insulation is required in the wing.

Reverse thrust is more easily achieved without damage to the wings.

Engines are easily accessible for servicing.

It is relatively easy to modify the design to use a different engine.

---

**Fig 7-6** Engines in Under- Wing Pods



---

Weight is moved away from the fuselage, reducing bending loads on the wings in flight. Underslung wing pods also help to offset the aerodynamic forces which try to twist the wing.

7. It would be unusual if there were no snags associated with any engine installation, and this case is no exception. Underslung pods have the following disadvantages:

The same yaw problems exist as with other wing installations in engine-out cases.

Heavy loads can be placed on the wing and engine mountings if violent manoeuvres are necessary during flight, and during landings.

Ground debris is more easily drawn up into the engine intake, where it can cause extensive damage (this is known in the RAF as FOD (foreign-object damage)).

Taller and more complex undercarriages are needed to keep the pods clear of the ground.

## CHAPTER 8

### UNDERCARRIAGES

*What is an undercarriage used for?*

1. An undercarriage is needed by all aircraft which operate from land. It is required to:

Support the aircraft on the ground.

Absorb the shock of landings and provide smooth taxiing.

Withstand the side loads of crosswind take-offs and landings.

Give minimum rolling friction on take-off, minimum drag in the air and hold the aircraft at the correct attitude during the take-off and landing runs.

Withstand large braking loads during landing.

Be as light as possible since an undercarriage is dead weight when airborne.

2. An aircraft is usually supported on the ground by three units - two main wheels and a nose wheel (Figure 8-1). Some light aircraft have a tail wheel instead of a nose wheel, but this arrangement is no longer common.

---

**Fig 8-1** two Main-Wheels and a Nose-Wheel



---

3. The main advantages of the nose-wheel or tricycle layout are:

With a steerable nose wheel, ground manoeuvring is easier.

The pilot's view is improved.

The aircraft floor is horizontal when on the ground.

Aerodynamic drag on take-off is reduced, giving much better take-off performance.

Directional stability on the ground is improved, because the C of G is forward of the main wheels.

Braking is more straightforward, and brake parachutes can be used.

There is less tendency to float and bounce on landing, making landing easier.

4. The main disadvantages are:

Nose wheels need to be stronger and therefore heavier than tail wheels.

More damage is done to the aircraft if the nose wheel collapses.

#### SHOCK ABSORBERS

##### ***Types of Shock Absorbers***

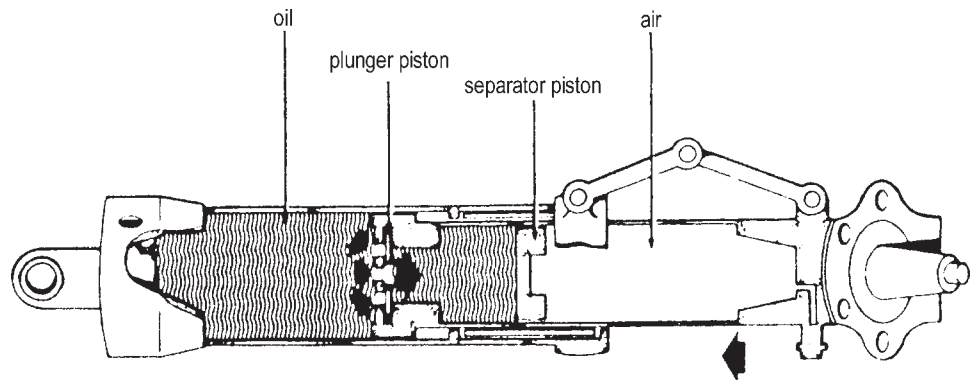
5. When an aircraft lands, a large force is applied through the undercarriage as it touches the ground. This may be up to three times the weight of the aircraft for transport aircraft, and up to eight times for an aircraft landing on the deck of a ship. To prevent damage to the structure, and to stop the aircraft bouncing, this shock must be absorbed and dissipated by the undercarriage.

Several methods are used to absorb taxiing and landing shocks. On light aircraft, the undercarriage may be just a piece of spring steel, with perhaps a rubber mounting in the aircraft fuselage. On heavier aircraft a telescopic shock absorber known as an oleo leg is almost always used.

6. Most service aircraft, as well as most civil transports, are fitted with oleopneumatic or oil-compression type undercarriages. The operation of both units is very similar, the difference being that an oleo-pneumatic unit compresses air or nitrogen gas, and an oil-compression unit (often known as liquid spring) works by compressing oil, as the name suggests. If you study Figure 8-2, you can see that compressing the strut reduces the volume inside and compresses the gas or oil, like operating a bicycle pump. Any tendency to bounce is prevented by forcing the damping oil through small holes, so that the strut can only extend quite slowly. The

gas or oil will stay slightly compressed when it has the weight of the aircraft on it, so it is cushioned whilst taxiing.

**Fig 8-2** Undercarriage Oleo-Pneumatic Leg



7. The operation of nose-wheel shock absorber units is similar, but their construction differs slightly in that they are usually designed to allow the nosewheel to be steered, by rotating the entire unit, or by steering motors on larger aircraft. Often the nose-wheel steering must be capable of being disconnected for towing.

8. To make sure the aircraft tail does not hit the ground on take-off or landing, the main wheels must be behind the centre of gravity. If they are too far back, very high loads will be taken on the nose wheel during landings, which may cause it to collapse. Main units are often retracted into the wings. All of these factors mean that the undercarriage positions must be very carefully designed.

9. Each main-wheel unit consists of a single, double, tandem or bogie unit, of four or more wheels (Figure 8-3). There are even more variations than this, but they are not common. As aircraft become heavier, the loading on a single wheel increases, leading to a great increase in the damage done to runways. By having the weight spread over a number of wheels, the contact pressure of the undercarriage is reduced, by spreading the load (Figure 8-4). This leads to reduced undercarriage weight and increased safety if a tyre bursts on landing. The Boeing 747 has 18 wheels - four main units, each a four-wheel bogie, and a double nose-wheel unit.

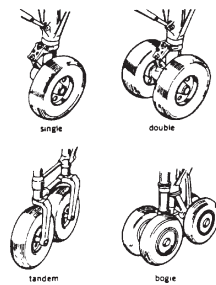
10. A variation of the tandem arrangement is the jockey unit, which comprises two or three levered legs in tandem on each side of the fuselage, sharing a common horizontal shock absorber. Amongst the advantages of this design are excellent

rough-field performance and the ability to lower the aircraft down (kneeling) for easier loading. The units also retract into a small space, without penetrating into the load space. This makes this arrangement ideal for transport aircraft like the Hercules.

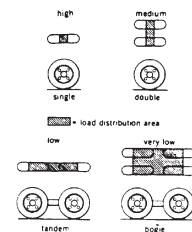
RETRACTION

**Undercarriages in Flight**

11. An undercarriage causes a lot of drag in flight, so it is retracted into the wings or fuselage in most aircraft, except when needed. In most cases, a hydraulic jack is used to pull the undercarriage legs, about a pivot at the top. The doors to the undercarriage well may be attached to the legs, or may use separate jacks to open and close them.

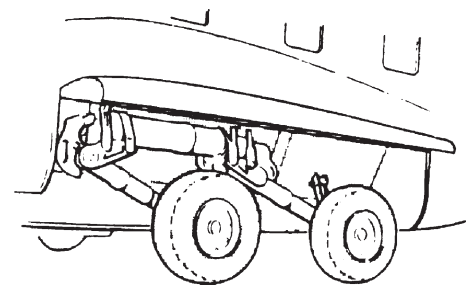


**Fig 8-3 Main-Wheel Units**

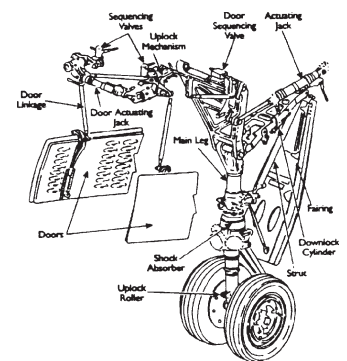


**Fig 8-4 Load Distribution Areas**

**Fig 8-5 Jockey Unit**



**Fig 8-6 Undercarriage Retraction Mechanism**



It is important that the doors open before the undercarriage units extend or retract, and close afterwards, so a sequencer valve is used to control the supply of hydraulic fluid.

In many cases the undercarriage needs to fit into a very small space, and the units may be turned, twisted or folded to allow this. If the hydraulic system fails, the undercarriage must be capable of being lowered so that the aircraft can land safely. Nose wheels are normally retracted forwards, so that aerodynamic drag will help them to extend under gravity in an emergency. It is common for pressure bottles to be fitted, which store enough pressure to allow the undercarriage to be extended once, if the system fails.

***Ground locks on undercarriages***

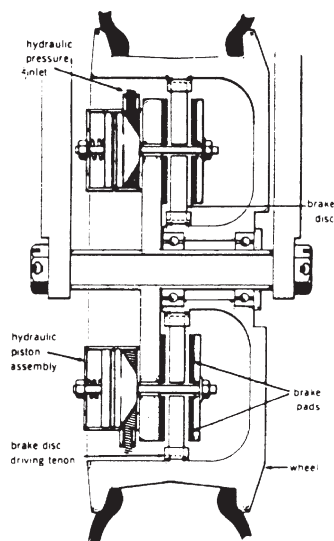
12. To prevent an undercarriage collapsing on the ground, and to hold it firmly in its retracted position in flight, uplocks and downlocks are fitted to hold the units in place. These are unlocked as part of the extension and retraction sequence. It would be catastrophic if the undercarriage were retracted accidentally with the aircraft on the ground, so ground locks are fitted, disabling the retraction mechanism.

***Types of brakes***

13. The high weights and speeds at which many aircraft land mean that the braking system must be capable of absorbing and dissipating very large amounts of heat, as the energy of motion is converted into heat. There are two main types of brake - drum brakes and disc brakes. The drum brake is rarely used, because it suffers from poor heat dissipation, causing the brakes to overheat and fade - lose their braking effectiveness as their temperature increases during braking.

14. Disc brakes are much more effective at dispersing the heat produced, and maintain their effectiveness during long periods of heavy braking. They consist of a disc or series of discs of aluminium alloy, steel, carbon or other material, gripped between pads of friction material. These pads are forced against the discs by pistons under hydraulic pressure. Control is usually achieved by placing a toe pedal for the brake on each side on its respective rudder pedal. These can then be operated differentially by the pilot, giving the ability to steer the aircraft by applying different amounts of braking on each main wheel. Applying the brakes equally on both main units allows the aircraft to be braked smoothly in a straight line. Large aircraft may have quite a number of discs in each wheel, to get the required braking forces and heat dissipation.

**Fig 8-7 Disc Brake Unit**



**Anti-skid unit**

15. An anti-skid unit, called a Maxaret unit, prevents skidding by detecting when the wheel or wheels on any unit stop turning, and momentarily releases brake pressure on that unit only. This gives the aircraft the ability to stop in the shortest possible distance without loss of control. Similar units, known as ABS, are fitted to many cars, and work in the same way.

**Other types of braking**

16. Another form of braking is air brakes, used in flight, which consist of large plates fitted to the fuselage which can be lifted into the airflow when required. They cause a large increase in drag to slow the aircraft. After touch-down, reverse thrust of jet engines can be deployed, by moving doors into the jet exhaust to deflect the flow forwards. Turbo-prop engines can achieve a similar effect by changing the pitch of the propeller to reverse the airflow.

## Self Assessment Questions

***Do not mark the paper  
in any way - write your  
answers on a separate  
piece of paper.***

1. What is an oleo leg?
2. What controls the supply of hydraulic fluid in an undercarriage?
3. What are the 2 main types of brakes?

# CHAPTER 9

## CONTROLS

### Introduction

#### ***Types of controls in aircraft***

1. All aircraft have to be fitted with a system that will enable the pilot to manoeuvre the aircraft in flight. There are usually three sets of control surfaces positioned near the extremities of the aircraft, ie the wing tips and tail, to give the longest possible lever about the centre of gravity (C of G). In your study of Principles of Flight, you have learnt about aircraft controls, and how they are used to manoeuvre the aircraft. They are:

Elevators or foreplanes for control in pitch.

Rudder for control in yaw.

Ailerons for control in roll.

#### ***Elevators***

The elevators are hinged to the tailplane spars, or all-flying tailplanes or foreplanes may be used; the rudder is hinged to the fin spar; the ailerons to the wing rear spar.

With fighter aircraft, computer control can be used to control an unstable aircraft, which would otherwise be unflyable. This makes the aircraft very responsive, and gives the manoeuvrability needed to gain an advantage over an opponent. A delta configuration is often used, with foreplanes or canards near the nose of the aircraft, rather than the conventional rear tail to provide pitch control.

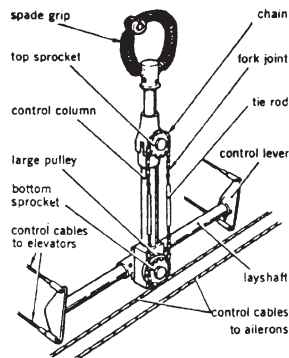
2. With the increasing use of computers in aviation, most control circuits, except for the smallest of aircraft, use computers in some way, either to assist or to control the aircraft entirely, by processing demands from the pilot. The autopilots in modern transport aircraft are becoming increasingly sophisticated, and some are now capable of flying the aircraft throughout the whole flight, including take-off and landing.

### CONTROLS

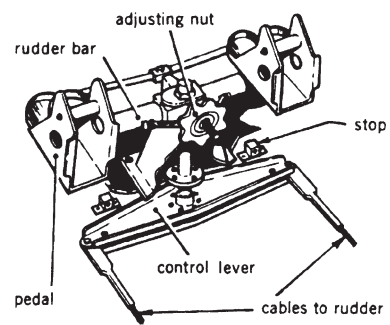
#### ***The Control Column***

3. The control column (often known simply as the stick) operates the elevators and ailerons. In large transport aircraft, the stick may be replaced by a device which looks a little like a car steering wheel, called a yoke, or a side-stick device may be

used (see paragraph 7). The rudder bar (Figure 9-2) operates the rudder. Movement of the control column or rudder bar is transmitted to the respective control surface by cables or push-pull rods in small aircraft. In large or fast aircraft, the forces required to move the controls are too large for the pilot to operate them, and a system of power operation or power assistance is required, using actuators.



**Fig 9-1** Control Column Operation



**Fig 9-2** Rudder Bar Operation

4. Although the way in which the controls are operated varies from one aircraft to another, a given movement of the control column will always make the aircraft turn in the same direction:

Moving the control column forwards makes the aircraft pitch nose down;  
backwards lifts the nose;

Moving or turning the controls to the left raises the left aileron and lowers the right one, making the aircraft roll to the left;

Pushing the right rudder pedal deflects the rudder to starboard (right), and causes the aircraft to yaw to starboard.

### STICK FORCES

5. As aircraft speeds increase, so air flows faster over the control surfaces and this greatly increases the air loads the pilot has to overcome to move the control surfaces. In other words, he must push or pull harder on the controls to move the elevators, etc. The air loads increase as the square of the speed, as you have seen in Chapter 1. These air loads on the control surfaces cause the pilot two main problems:

To hold the controls against the air flow could be very tiring, so the designer fits some method of adjustment to the control surfaces which the pilot can operate in flight. In this way, he trims out the control loads and so can hold the aircraft in any attitude for a long time without becoming tired.

As aircraft speeds increase the forces on the control surfaces become so great that the pilot finds it difficult to move them at all. As you have seen, hydraulic power can be used to help the pilot to move the surfaces, or to move them for him. But before this stage is reached there are various aerodynamic ways of using the airflow itself to help the pilot to move the surface. Some of the devices which do this are balance tabs, inset hinge and horn balances.

***Methods of operating controls***

6. There are several methods of operating controls, and these fall into the categories of manual, power-assisted and power-operated control systems. These may be used in combination with, for example, power-assisted controls being used for the rudder and elevators and manual (unassisted) controls for the ailerons, which often are easier to move. These various ways of moving control surfaces have advantages and disadvantages.

For large aircraft and many fast jets, the use of power controls is the only feasible choice, because the controls would be so difficult for the pilot to move, and because of the control circuits used. For light aircraft and small commercial aircraft, the simplicity, lightness and cost of manual controls may be used to best advantage, and no power assistance is necessary.

For those aircraft between the two extremes, power assistance is often the ideal solution, with some of the control effort being applied by the pilot and some assistance by mechanical actuators. This takes advantage of smaller actuators, gives the pilot more feel, since he is still operating the control surfaces directly, and gives a manual backup if the power-assistance system fails.

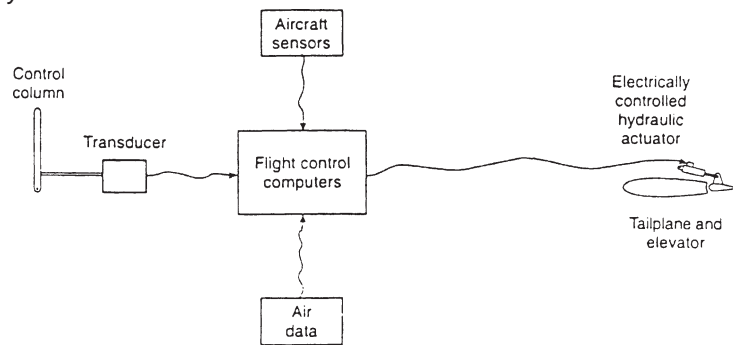
COMPUTERS AND FLY-BY-WIRE

***Fly-by-wire aircraft***

7. Because of the speed of digital computers, it is possible to fly an unstable aircraft; the speed of the control computers is high enough to make the constant corrections which can overcome the instability of the aircraft aerodynamics, giving

the pilot the impression of a stable but highly responsive fighter aircraft. The extreme responsiveness comes about because any manoeuvres are assisted by the aircraft's instability.

**Fig 9-3** Fly-by-Wire System



For a fighter aircraft, this can present an enormous advantage in combat. This system is commonly known as fly-by-wire, because no control cables or linkages are run inside the aircraft; all control connections are made by electrical cable, and these connect directly to electric or hydraulic actuators.

#### **Fly-by-light aircraft**

Another variant which is just becoming available is fly-by-light, where the control signals are transmitted by fibre optics rather than electrical cables.

8. For transport aircraft, extreme control responsiveness is obviously not required, but computers and fly-by-wire systems are still useful, because their rapid information processing increases safety by preventing pilots asking the aircraft to do anything it is not capable of doing. Since all control demands are processed by the computer, rather than fed directly to the controls, any control movements which could endanger the aircraft, for instance by causing a stall, can be ignored. This creates an aircraft which is almost impossible to stall, and stalling is a major reason for a high proportion of aircraft accidents.

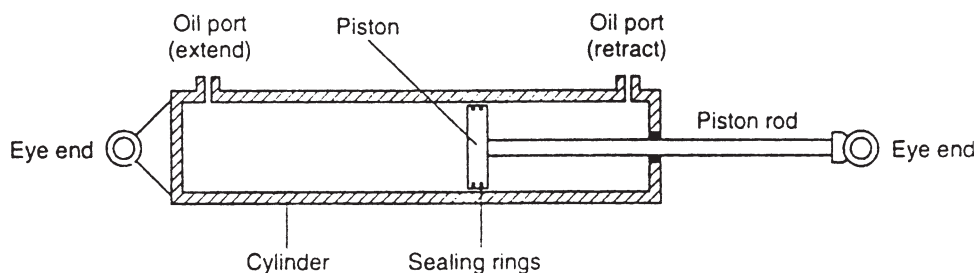
9. Computers can break down, and software is notoriously difficult to free of errors, so all computers which are essential to the control of an aircraft must be triplicated. They operate on a voting system, where if one computer disagrees with the other two, it is outvoted, the majority decision carries and a computer failure warning is given.

In many aircraft, especially the older ones, computers are used only for the autopilot, and the outputs are used to move the aircraft controls; in this way the autopilot duplicates the actions of the pilot directly, and the control surfaces are deflected through the normal control route. There is more information on autopilots in the next chapter.

### ACTUATORS

10. With powered flying control systems, there is a range of possible actuators to choose from. The most common actuator for operating control surfaces, as well as many other moving parts, is the hydraulic actuator. This type of actuator provides high jack forces from a small unit. Hydraulic circuits operate at around 200 bar (3000 pounds per square inch). Because of its design, a hydraulic jack can create higher forces in extension (pushing) than retraction (pulling).

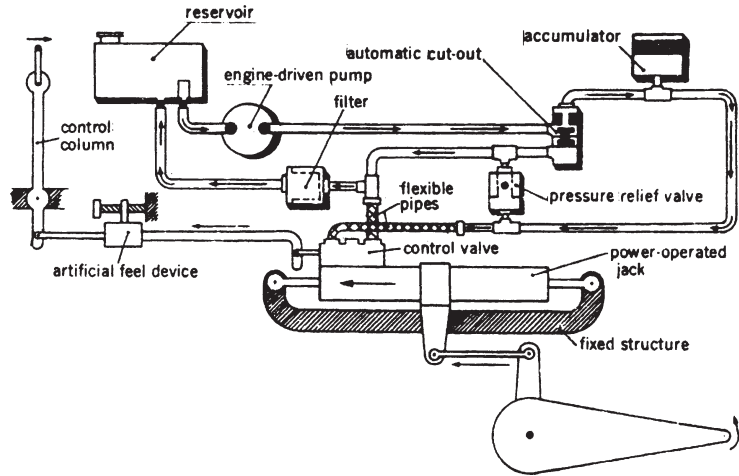
**Fig 9-4 Hydraulic Jack**



The hydraulic jack may be extended or retracted by allowing oil to flow to the relevant side of the unit until the correct position has been reached - this method is used for undercarriage jacks for example, where the jack is operated until it reaches the end of its travel. Where the system is required to move to a specific position, a servo actuator is normally used. A servo actuator will follow the control linkage automatically. This type of actuator can be used for power-operated and power-assisted controls, where the control linkage is also connected to the control surface being moved, the actuator helping the pilot to move the control surface.

11. Power Failures - Powered and Power-Assisted Systems. All aircraft having power-operated or power-assisted controls need to have an alternative control system in case the main system fails. The alternative may be a separate hydraulically-operated system or a manually-operated system. If the back-up system

**Fig 9-5** Power-Operated Control System



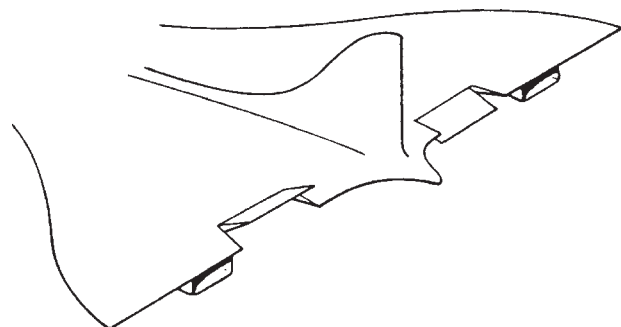
is manually-operated, failure of the hydraulic supply will cause reversion to manual control, with a sudden increase in stick forces. To avoid this, many aircraft have a hydraulic reservoir, which gives a supply for a small number of control movements whilst the pilot is slowing down and trimming the aircraft in preparation for flying on manual control.

OTHER FORMS OF CONTROL SURFACES

**Elevons**

12. Elevons. Some tailless aircraft with swept or delta wings combine the functions of the elevators and ailerons in control surfaces called elevons. Fore and aft movement of the control column will lower and raise both surfaces together which act as elevators. Side to side movement causes the elevons to move in opposite directions to give the effect of ailerons. Any combination of these movements causes a mixture of these actions, to give combined pitching and rolling manoeuvres (Figure 9-6).

**Fig 9-6** Elevons



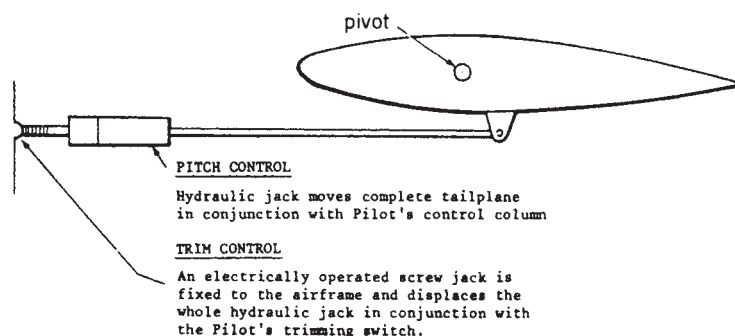
13. Canard controls. This type of control surface usually replaces the conventional tailplane, and is often used together with a delta wing. Deflecting the foreplane upwards increases the lift, lifting the nose and causing the aircraft to pitch up.

**Fig 9-7** Canard Foreplane (EF 2000)



14. The All-Flying Tail. At high Mach numbers the elevator loses much of its effectiveness. This causes a serious decrease in the accuracy with which the flight path can be controlled, and in manoeuvrability. To overcome this problem the complete tailplane can be moved to control the aircraft in pitch. Some form of power assistance is usually fitted to provide the high forces needed to move the tailplane.

**Fig 9-8** All-Flying Tail

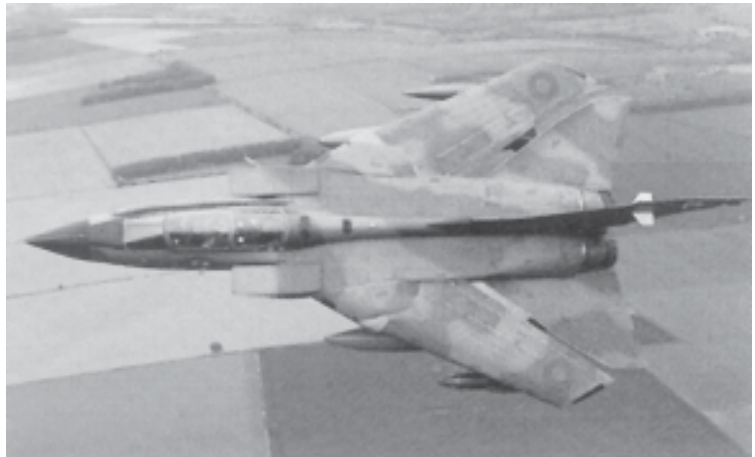


With the all-flying tail, full and accurate control is maintained at all Mach numbers. Forward movement of the control column increases the incidence of the tailplane to lift the tail and lower the nose.

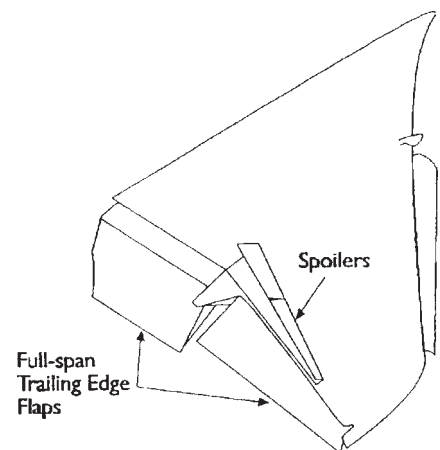
15. The Variable-Incidence Tailplane. This is used on some aircraft as an alternative to trim tabs. By varying the incidence of the tailplane the pilot can balance out control loads to avoid having to hold a constant load on the controls. This method is more effective than trim tabs at high speeds.

16. Tailerons. These are similar in operation to elevons, but in this case the two halves of an all-flying tailplane are moved independently to do the job of ailerons and together to act as elevators (Figure 9-9). This allows much larger flaps to be fitted to the trailing edge of the wing, because separate ailerons are no longer needed. On some aircraft, the tailerons are supplemented by spoilers on the wings, which act in the same way as the up-going aileron, but still allow large flaps to be fitted (Figure 9-10).

**Fig 9-9** Tailerons



**Fig 9-10** Spoilers and Full-Span Flaps



## Self Assessment Questions

***Do not mark the paper in any way - write your answers on a separate piece of paper.***

1. What do the elevators or foreplanes, rudder and ailerons control in an aircraft?
2. Give 3 categories of operating controls.

## CHAPTER 10

### AUTO-PILOT AND RELATED SYSTEMS

#### PURPOSE OF AN AUTOPILOT

***Look no hands***

1. Many flights in modern aircraft last quite a long time, often for several hours. Even in fighter aircraft, a large number of Combat Air Patrol (CAP) sorties are flown, where the aircraft stays airborne for a number of hours. To make the job of a pilot as simple as possible, routine flying on a given heading can easily be performed by a mechanical or electronic system. This system is called an autopilot. With the use of computers, a much wider range of flying can be carried out by the autopilot, and it is possible to make a complete flight with little or no pilot input. This relieves the pilot of routine tasks, which can cause fatigue, and leave him free to concentrate on other aspects of the flight.

2. If the autopilot is to be of practical use, it must be able to keep the aircraft in straight-and-level flight, or in steady climbs and descents, when required. It would also be very useful if it could carry out simple turns when a change of heading is needed. This is much more difficult, because it needs a correct mixture of the three main controls - elevators, ailerons and rudder.

Modern autopilots are often much more sophisticated than this, and can carry out complex manoeuvres such as landings safely and reliably. When an F-14 fighter takes off from the deck of an aircraft carrier, by catapult, the autopilot system controls the first stages of the take-off, with the pilot prevented from taking control until the aircraft is airborne.

#### PRINCIPLES OF OPERATION

3. This section describes how the simplest forms of autopilot work. To control an aircraft requires two main operations:

a way of detecting when the aircraft has strayed from the required flight path.

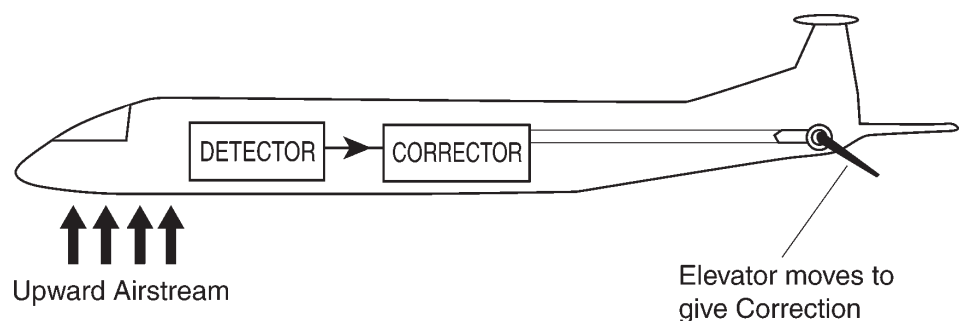
a system for calculating what control movements are needed to correct this error, and of making those control movements.

Using this system, if the flight path of the aircraft is disturbed, perhaps by an upgust (a change in wind direction which makes the aircraft pitch nose-up), a control movement is needed which brings the nose of the aircraft back down, i.e. moves the elevators down, so that level flight is restored. This control movement needs to be proportional to the size of the disturbance, so that a small disturbance leads to a small correction. Because the aircraft needs to be controlled in three axes, pitch, roll and yaw, three Channels are needed in the autopilot, one to control in each axis.

**How an auto-pilot works**

4. The device which detects the disturbance is a rate gyroscope. This is usually a spinning mass which is electrically driven. The gyroscope resists any disturbance by generating a force to oppose it, and this can be detected electrically by a pickoff. An electrical signal is given which depends on the or speed of this disturbance. The signal is then amplified, so that it can be fed to the second part of the system, the corrector circuit (Figure 10-1).

5. The disturbance correctors are servo-motors which are designed so that the speed at which they travel is proportional to the size of the signal applied to them.



**Fig 10-1** Correcting a Disturbance in Pitch

Because this signal comes from the detector, this means that the larger the disturbance the faster the servo-motor will turn. As the aircraft returns to its original flight path, this signal will reduce, and the correcting action will be reduced as well.

6. Apart from the basic spinning-mass type gyroscope, there are many other types, which use vibration or light to measure the speed of disturbance. In particular, the ring-laser gyroscope is becoming more common, because it is more accurate

and much more reliable than a mechanical gyroscope. It consists of a triangular or square ring of glass, which is hollow. A laser beam travels around the ring, reflected at the corners. If the gyroscope is rotated, the light will take a slightly longer or shorter time to travel around the ring. This tiny time difference can be detected, and an electrical signal produced in proportion to the speed of rotation.

### ***Drift***

7. The simple mechanism of controlling an aircraft's attitude described so far has some limitations, which need to be overcome. Because of the way in which the autopilot works, the aircraft will gradually move away from the heading and attitude set in the autopilot, which is known as drift. This requires another independent system which the autopilot system can use to check for gradual changes and correct them. To control an aircraft direction, especially at high speed, it is better to use ailerons in conjunction with the rudder, or even to use them instead of the rudder. So the autopilot can be set up to send correction signals from the yaw detector to the aileron corrector. This is known as cross-feed, and results in smoother corrections of yaw disturbances.

### RELATED SYSTEMS

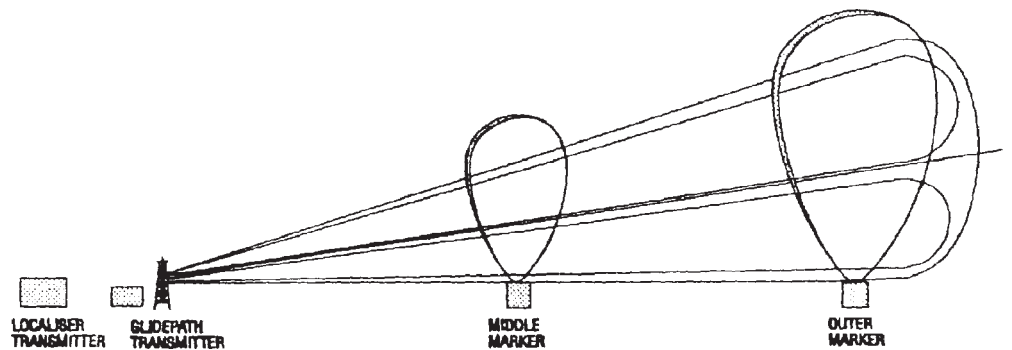
8. For these reasons, the autopilot used in most aircraft is much more complex than the simple model described here. By using computers, the autopilot can be used to control the aircraft in a wide range of manoeuvres, from simple turns to complex series of manoeuvres such as terrain-following. Control signals can be passed to the computer, which will then command the servo-motors to make the necessary control movements. The gyroscopes can be monitored to allow the system to keep track of the aircraft's attitude. This can have many applications:

### ***Instrument Landing System***

9. Instrument landing systems (ILS) use a signal from a transmitter close to the runway to give an indication to the pilot when the aircraft is on the correct approach path. This is useful when visibility is poor and the runway is not visible. ILS is not part of the autopilot system, it just gives the information to the pilot on a special instrument.

10. Autoland systems process information about the aircraft's height, position, heading and speed relative to the runway, using information from the ILS system in addition to aircraft data. They then generate instructions to the autopilot to fly the

Fig 10-2 Instrument Landing System (ILS)

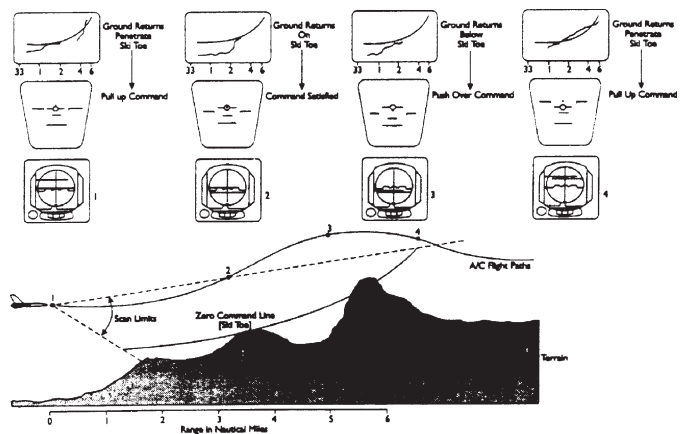


aircraft on a suitable heading to achieve a touchdown at the correct point on the runway. These systems are effectively fully automated versions of the ILS described in the previous paragraph, and are highly accurate, and a useful safety feature. Automated take-offs are also possible, using a pre-programmed take-off routine.

**Terrain - Radar**

11. Terrain-following systems use a special radar, which maps the ground in front of the aircraft. The system then predicts the control movements needed to fly the aircraft close to the ground without colliding with it. As with the autoland system, the autopilot is used to control the movements of the control surfaces. In this way, a ground-attack aircraft can fly at high speed at very low level, giving the minimum chance of being detected by enemy radar. The system is so fast that the aircraft flies at heights and speeds that a pilot would not be capable of controlling unaided (Figure 10-3).

Fig 10-3 Terrain- Following radar-Flight Path Indications



***Look - no pilot***

12. It is now quite possible to fly the aircraft automatically, by programming waypoints, arrival times, flight levels, etc into the autopilot system. The aircraft will set the speed, height and bearing as required, making automatic corrections for wind speed and direction, and allowing the flight plan to be modified at any time by the pilot. By combining some or all of these systems, an aircraft could fly an entire flight without pilot intervention. In the future, it is likely that many civil aircraft will not have pilots at all, but will be pre-programmed to fly a particular route unaided. System failure is largely prevented by having several back-up systems, and as a last resort the aircraft could be flown from the ground to complete a flight safely. The main problem with this would not be a technical one; it would be passenger resistance to a pilot-less aircraft. However, once it can be shown that automatic systems are safer than human pilots, this means of flying will be available.

## Self Assessment Questions

***Do not mark the paper  
in any way - write your  
answers on a separate  
piece of paper.***

1. What does ILS mean?

# CHAPTER 11

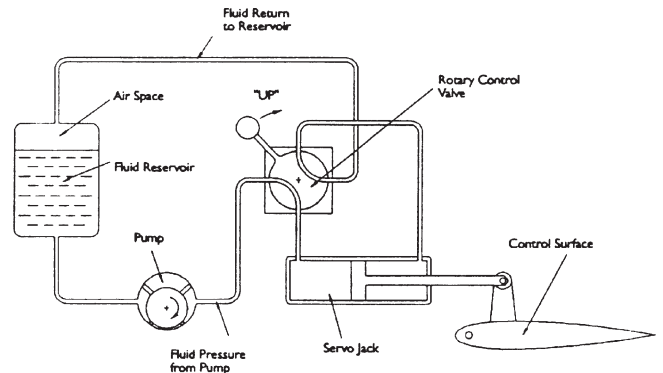
## AIRCRAFT SYSTEMS

### HYDRAULIC SYSTEMS

#### ***How hydraulic systems work***

1. Hydraulic systems are a convenient way of providing the force required to retract and extend undercarriages, and to operate flaps and wheel brakes. They are also widely used to move control surfaces, such as ailerons and elevators, in power-assisted and power-operated control systems. Although the pumps and pipework needed to supply pressurised hydraulic fluid around the aircraft might seem to be quite heavy, the system can be much lighter than an electrical or mechanical system. This is because of the high pressures used, which lead to small units of high power.
2. Hydraulic systems use a special type of oil to transmit pressure. A pump pressurises the oil to about 210 kilogrammes force per square centimetre. This means that a hydraulic jack capable of lifting a one-tonne family car might only be about 25mm diameter. The hydraulic jack that is used to create this movement looks like Figure 11-1.
3. The flow of oil into the jack is controlled by a valve, and it is designed so that oil can flow into one side of the jack to make it extend, and into the other to make it shorten or retract. By controlling the speed that the oil flows into the jack, the speed of its extension or retraction can also be controlled. When oil is fed into the right side of the jack, the pressure acting on the face of the piston creates a force which pushes the piston to the left. This causes the jack to extend. The movement of the piston pushes oil out of the left chamber. In a similar way, pumping oil into the left chamber retracts the jack, pulling control surface or undercarriage leg with it.
4. The hydraulic oil needed for this movement is passed around the aircraft in pipes. Some are pressure lines, taking the oil from the pump to the control valves. Other pipes connect each control valve to its jack, or actuator. When the jack retracts, the oil that is expelled to allow the jack to move passes into low-pressure return pipes, which take the oil back to the reservoir, where it is stored until it is needed again.

**Fig 11-1 Simple Pump-Powered Hydraulic Jack**

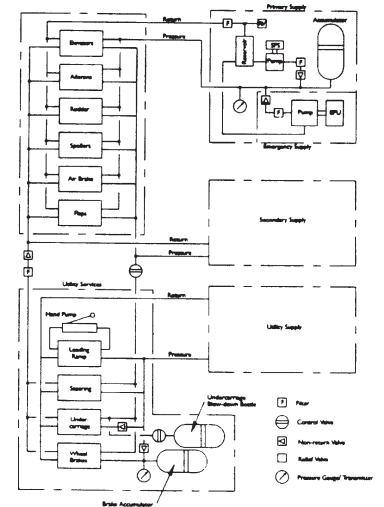


5. An aircraft hydraulic system is quite complicated, but is made up of a lot of very simple circuits. The system is similar in many ways to a set of electrical circuits, although of course a flow of oil is being used rather than a flow of electricity.

**Safety Systems**

6. With any system which is vital to the safety of the aircraft, the designer needs to make sure that if a component fails it will not create a danger to the aircraft. This is usually done by duplicating the control systems - each control surface is moved by two or more jacks and their associated pipework. In an emergency, it is sometimes possible for the crew to operate a hand-pump to carry out simple tasks like lowering the undercarriage. It is more common for the aircraft to carry an emergency supply of pressurised nitrogen gas, which can be used to push the hydraulic fluid through the system when needed. Because only a small amount of gas can be carried, this lasts just long enough to allow the aircraft to land safely if the hydraulic pumps fail.

**Fig 11-2 Typical Hydraulic Circuit**



Hydraulic fluid is a type of oil, so it could be a fire risk, especially when it is at high pressure, because any small hole will cause a fine mist of oil to be produced. Hydraulic fluids are usually inhibited, or treated, to reduce the likelihood of them burning.

7. Because hydraulic oil is almost incompressible, the position of the jack can be controlled very accurately, if necessary. This is very useful for wing flaps, for example, where different amounts of flap are needed for landing and take-off. This incompressibility of hydraulic oil is an important feature of hydraulic systems, and it is important that all traces of air are kept out of the system. The high operating pressures of hydraulic systems mean that small jacks can produce large forces, so they can easily be fitted into very small spaces.

***How an undercarriage works***

8. The use of valves to control hydraulics means that these valves can be made to operate automatically. Using sequencing valves, a series of operations can be carried out just by making a single selection. For instance, retracting an undercarriage requires a series of movements that must be carried out in the correct order, and at the correct time. Selecting 'undercarriage up' will begin a sequence of operations, starting with opening the undercarriage doors, then unlocking the undercarriage downlocks, lifting the legs into their bays, locking the legs in the stowed position, then closing the undercarriage doors. The hydraulic pressure at various points in the system, and/or the positions of jacks and locks, can be used to inform the crew when the undercarriage is locked and unlocked, by means of a set of lights.

OperationAction

Open undercarriage doors

Release down-locks

Retract undercarriage

Up-locks automatically engaged as undercarriage reaches fully-up position

Close undercarriage doors

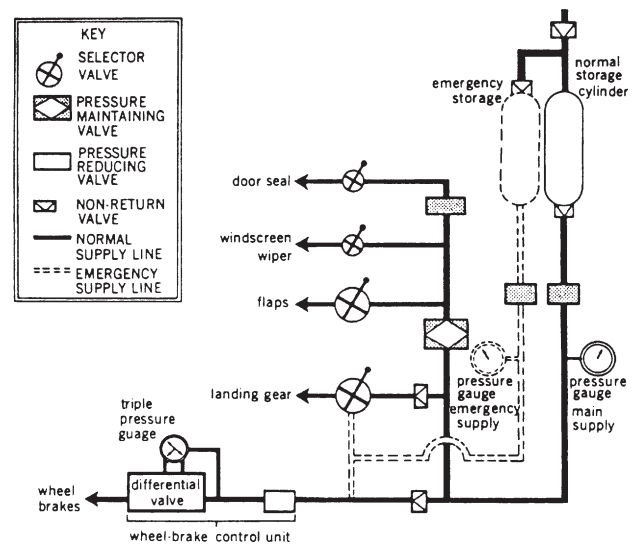
PNEUMATIC SYSTEMS

**Use of air in pneumatic systems**

9. Pneumatic systems work in a very similar way to hydraulic systems. The difference is that in pneumatic systems high-pressure air is used instead of hydraulic fluid. Because air is much more compressible than fluid, it is much easier to store pressure, using reservoirs. This can give a reserve of power for short bursts of very heavy operation, or for emergency use if the system fails.

10. However, the compressibility of air can be a major disadvantage. Pneumatic systems lack the instant response that hydraulic systems provide, and the rate of movement of pneumatic actuators is depends strongly on the load, or the force which resisting the movement. This compressibility also means that the position of systems needing partial movements, such as control surfaces, cannot be controlled with any degree of accuracy.

**Fig 11-3 Simplified Pneumatic System**



11. Another disadvantage of pneumatic systems is the inefficiency in transmitting power, because energy is lost in compressing the air. This does not occur with hydraulic fluid.

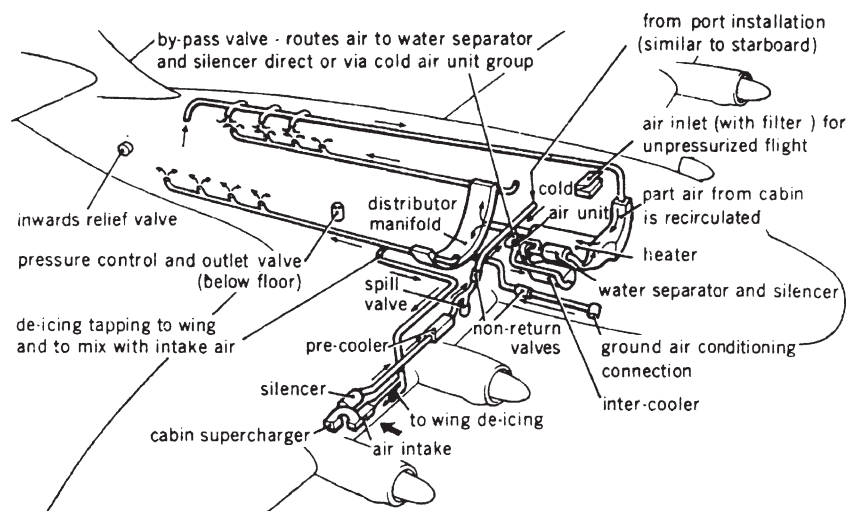
**How aircraft use hot air from engine**

12. Because of these major disadvantages, many aircraft are not fitted with a pneumatic system. However, many aircraft use compressor bleed air to do certain tasks. Because gas turbine engines generate hot air at relatively high pressure, a small amount of this air can be used to de-ice the leading edges of wings, tailplanes and engine intakes. Bleed air is used on many aircraft to supply the power and heat

to operate cabin pressurisation and air conditioning systems. This air is not passed directly into the cabin, but through a heat exchanger, where it heats up cold incoming air, and through a cold-air unit.

The cold-air unit acts like a turbocharger, with the turbine taking power from the bleed air to drive a compressor. Because the incoming air is drawn directly from the outside, it can be at very low pressure, depending on the altitude of the aircraft. The compressor raises the pressure of the air to a comfortable level for the crew and passengers, equivalent to about 2500m for passenger aircraft and up to 7500m for combat aircraft, where the crew also use an oxygen mask.

13. The air temperature is controlled by mixing high-temperature air from the heat exchanger, with cold air which has by-passed it, in the correct proportions. The humidity or moisture content is also important, and this is controlled by adding the required amount of water, as determined by a device called a humidistat.



**Fig 11-4** Air Conditioning Systems

ELECTRICAL SYSTEMS

**Use of electrical power in aircraft**

14. Most modern aircraft have airborne systems which require a large amount of electrical power to operate. These systems include radio, radar, navigation aids, aircraft instrumentation, weapon aiming and control, and engine starting. With flyby-wire systems, the demand on electrical supplies is even greater. Electrical power is also widely used to control hydraulic and pneumatic systems and their associated indicators.

**Electrical generators in aircraft**

15. It would be impossible to store the amount of electrical energy needed to supply all of these systems for an entire flight, so the electrical supplies needed are generated during flight. An aircraft electrical system will typically consist of two generators, driven by the aircraft engine or engines through a suitable gearbox. Most generators must be driven at a constant speed, regardless of the engine speed, and this is achieved by using a constant-speed drive unit. Using two generators ensures that the supply will be maintained even if an engine fails.

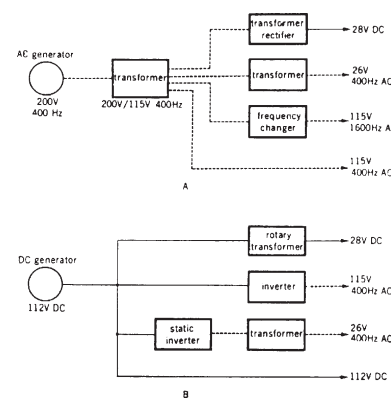
16. A small amount of energy is usually stored in batteries, sufficient to start the engines or for running essential supplies only for a short time in an emergency. These batteries are recharged during normal operation. Some aircraft have a ramair turbine (RAT), which takes energy from the outside airstream to turn a generator in an emergency. Many aircraft are fitted with an auxiliary-power unit (APU). This is a small gas-turbine engine which drives a generator to supply electrical power when the aircraft is on the ground, or in an emergency. The APU is usually used to supply pressurised air to start the main engines, and may also supply the cabin ventilation on transport aircraft.

**Electrical Power Supplies**

17. Except for the smallest of aircraft, the electrical power supplies are standard on all aircraft. Two supplies are provided, alternating current and direct current:

115 volt AC, 400 Hz, 3-phase. This is quite similar to the mains power supply in the home. It is used for most systems in the aircraft which require reasonable amounts of electrical power.

**Fig 11-5 Aircraft Electrical System**



28 volt, DC. This is used for most electronic systems, provided they do not require large amounts of power. It is also used for cockpit instrumentation, because its low voltage makes it much safer.

18. Many aircraft systems, particularly radar and navigation equipment, need electrical supplies at different voltages and frequencies to these. However, from the basic supplies it is relatively easy to convert them to the needs of particular equipment. The conversion is usually carried out inside the item of equipment requiring it.

### FUEL SYSTEMS

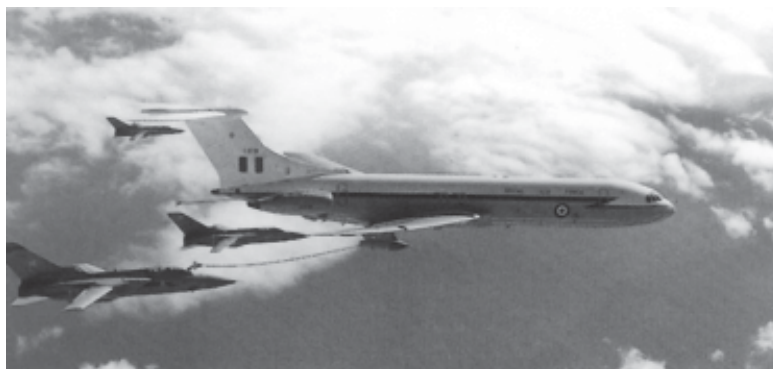
#### ***How an aircraft stores fuel***

19. An aircraft in flight uses a large amount of fuel, perhaps as much as 10,000 gallons per hour for a very large aircraft at take-off thrust. So a huge volume of fuel needs to be stored in the airframe if the aircraft is to have a reasonable flying time. Most is stored in the wings, but many aircraft also store fuel in the fuselage, and sometimes even in the tail. The fuel is stored in sealed compartments, or flexible fuel bags may be incorporated where sealing of the structure is not possible. Military aircraft frequently make use of external drop tanks; these are used to carry large extra volumes of fuel to give good Endurance (flight time), but can be jettisoned in an emergency or for combat, so they do not restrict the aircraft performance.

20. As the fuel is used, the centre of gravity of the aircraft will change, so the fuel will often need to be moved between tanks to keep this within acceptable limits, or the aircraft stability could be affected. To allow this movement of fuel, and of course to supply the fuel to the engines as required, a system of pumps and valves is fitted. To avoid boiling off of the fuel at high altitudes where the air pressure is low, the fuel tanks are pressurised.

21. The aircraft will usually be refuelled through a single refuelling point. From this point the fuel-management system distributes the fuel as required to the various tanks in the aircraft. In many cases, the amount of fuel an aircraft can carry is not enough to provide the endurance or range required. Air-to-air refuelling, from a specially-adapted tanker aircraft, can be used to supply the extra fuel needed. The aircraft will rendezvous with the tanker at a pre-determined point, and the tanker will trail a specially-designed refuelling hose. A probe on the aircraft connects to this hose, and fuel is transferred. This method needs good navigation to meet the tanker, and steady flying to achieve fuel transfer.

**Fig 11-6 In-Flight Refuelling**



## WEAPONS

22. There is a huge range of weapons fitted to modern aircraft, and the choice depends what job the aircraft is intended to do. The range of weapons can be split into three main categories: fighter weapons, such as guns and air-to-air missiles (AAMs); ground/sea attack weapons, such as bombs and air-to-surface missiles (ASMs); and electronic weapons, such as electronic countermeasures (ECM) and flares. These groupings are not absolute, because for instance guns are used widely for ground attack.

### AAMs, Guns and Rockets

23. Air-to-air missiles are the first choice for air defence (fighter) aircraft. They have a much greater range than guns, and the aircraft does not need to pointing exactly at the target.

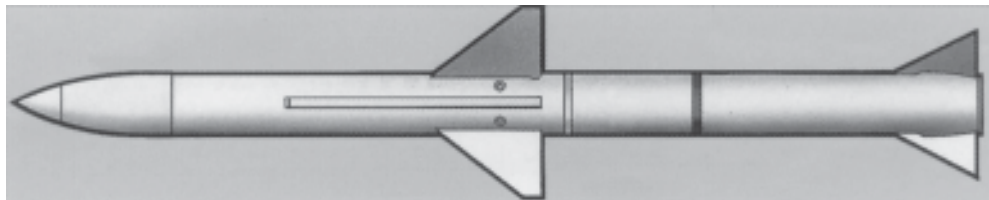
**Fig 11-7 Tornado With Air-to-Air Missiles Skyflash and Sidewinder**



The selection and launch are controlled by the pilot, using the aircraft's computer systems. When a target is within range, the details will be relayed to the pilot, usually through the head-up display, and sometimes by sound in his headset. The pilot then selects the missile to be fired, using the weapons selector switch, and fires the missile when he is in the best position to attack his target.

**How a missile is launched from aircraft**

24. When the launch signal is sent to the missile, a complex chain of events is set in motion. The launch sequence depends on which missile is to be fired, but will include firing the special batteries used to supply electrical power to the various parts of the missile, starting gyroscopes in the missile navigation system, telling the missile guidance system where the target is, and perhaps telling it what frequency is radar must operate on. The missile will also test all of its electronics to make sure everything is working properly. If all is well, the rocket motor which powers the missile will fire, and the missile will be launched. If the missile fails its self-check (a hang-fire), a signal will be sent to the aircraft computer, and another missile will automatically be fired.



**Fig 11-8** Skyflash Medium Range, Radar Guided Air-to-Air Missile

25. Missile guidance systems detect the position of the target by one of the following methods:

Active radar. The missile sends out a radar signal, and detects the reflection of this signal from the target. This gives the missile a lot of information about which direction it must go to intercept the target, how far away it is, even which direction the target is travelling in. Advantages are that the pilot of the launch aircraft can leave the target area and engage another target immediately, or make his escape, because after launch the missile is not dependent on the launch aircraft in any way (fire and forget). Also, because the radar is carried by the missile, the closer the missile gets to the target,

the stronger the reflected radar signal will be, so it is less prone to jamming. If the target tries to fool the missile by sending out a jamming signal, the missile can home in on this jamming signal (home on jam). Disadvantages are that the missile cannot carry as powerful a radar transmitter as the launch aircraft can, because of its small size and the amount of power available, so it has a smaller range than the next type, the semi-active missile.

Semi-active radar. This type of missile is very similar to the active radar missile, but the radar signal is sent out by the launch aircraft, rather than the missile. This means that the missile can detect the target at further distances (engagement range), but the launch aircraft must keep its radar on the target until the missile intercepts it. This is a huge disadvantage, because when the radar is switched on it appears rather like a huge light to an enemy aircraft, and leaves the launch aircraft very prone to attack. Semi-active missiles are still extensively used, because of their improved range, but are becoming less popular.

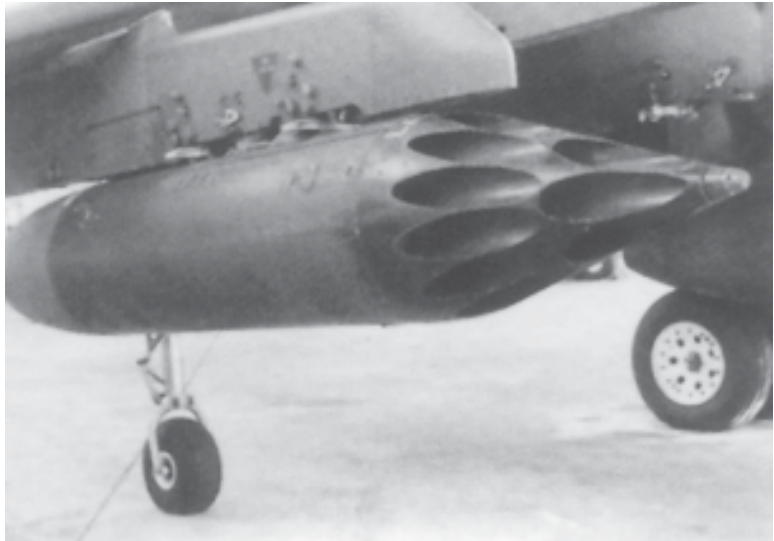
Infra-red. Unlike either of the previous systems, infra-red is usually passive. This means that the missile does not send out any kind of signal, but detects the infra-red emissions that everything sends out. This means that it gives no warning that it is on its way, and is less likely to give away the position of the launch aircraft. It is prone to distraction by flares ejected from the target, but modern missiles contain complex electronic processing systems which allow the missile to tell the difference between the target and a flare. This type of missile has a very limited range, because infra-red radiation is absorbed by the atmosphere, which means the missile is always flying in a kind of 'fog', but they are highly suited to close-range (less than 10 kilometres) combat.

**Aircraft Guns (cannon)** 26. Guns (cannon) are used as a back-up to guided missiles in air combat, because they have a much shorter range. A fighter aircraft will carry one or two cannon of 20 - 30mm calibre. They can fire at a very high rate (between 20 and 100 rounds per second, depending on the gun), and the ammunition is heavy, so they carry ammunition for only a few seconds of gun firing. For ground attack aircraft, the guns are used more often, and would be used against a variety of targets from tanks to trucks to trenches. Some aircraft cannon use special ammunition which is very effective against armour.

**Aircraft rockets**

27. Rockets are unguided (ballistic) weapons, often fired several at a time (salvos), against ground targets. Because they are unguided, they must be used at fairly short range, but can be very effective against unarmoured vehicles and ground installations.

**Fig 11-9** Pod for Unguided Rockets



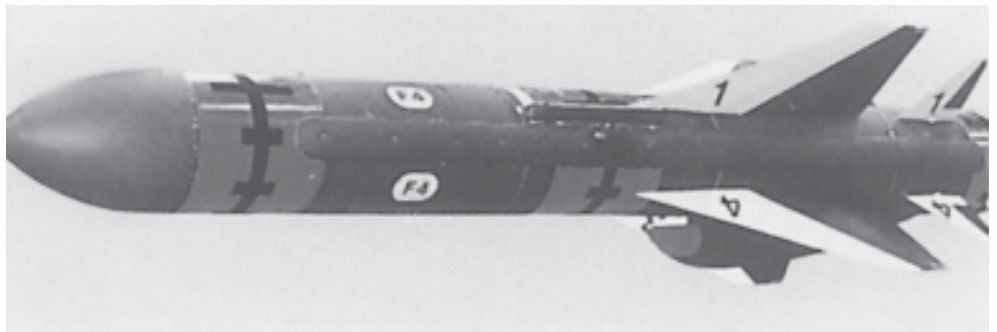
ASMs and Bombs

28. Air-to-surface missiles are very specialised weapons, and their design depends on the target they are intended to engage. Anti-armour weapons have warheads which are designed to penetrate great thicknesses of armour plating, even reactive armour (which explodes when attacked to deflect the effects of the warhead). Anti-radar weapons home in on radar installations and defeat them by destroying the antenna, using a shower of small fragments of shrapnel. Anti-ship weapons skim close to the surface of the sea, to delay their detection by the target.

**Fig 11-10** Air-Launched Anti-Radar Missiles (ALARM)



They are often able to 'see' the target in great detail, and identify a range of possible targets by comparing an image with images stored in a computer memory. It can be programmed to engage certain targets in preference to others, which means it may even fly past or over some ships to reach more important ones.



**Fig 11-11** Sea Eagle Anti-Ship Missile

**Cruise Missile**

29. A special kind of ASM is the cruise missile. This is a very long range missile (often over 100 km), which is programmed to navigate and fly using ground mapping terrain following, in a similar way that you or I might follow a map. They are extremely accurate, to within metres after a long flight. Cruise missiles are not just carried on aircraft - they may be launched from ships or land vehicles as well.

**Cluster bombs**

30. There is a wide range of bombs available, to perform a variety of different tasks. The simple high-explosive type can be used for many purposes, and comes in a range of sizes. A variation of this is used to penetrate great depths of concrete. Cluster bombs have a large number of small bomblets, which are scattered over a wide area after the bomb is released. Retarded bombs have a small parachute which slows the bomb down rapidly. This allows the bomb to be dropped very accurately from low altitude without risk to the aircraft.

## Self Assessment Questions

***Do not mark the paper in any way - write your answers on a separate piece of paper.***

1. What is used in hydraulic systems to transmit pressure?
2. What do pneumatic systems use to create pressure?
3. How do you control the humidity or moisture content of air in an aircraft?
4. How do you maintain a constant-speed drive in an aircraft electrical generator?
5. What 2 types of electrical power are used in an aircraft?

## CHAPTER 12

### THE COCKPIT

#### Introduction

***Cockpit - the most important part of an aircraft***

1. The cockpit is the point from which the pilot controls all of the workings of the aircraft. For a combat aircraft, the crew is confined to this area, so every single control necessary must be provided. These controls must be easily reached, easily operated and logically arranged, so that the pilot instinctively knows where to find them, and mistakes are avoided. All of the information the crew need to carry out their duties must be presented in a clear and logical way, and no vital indication must be missed. As far as the pilot is concerned, the cockpit is the most important part of the aircraft. Since it is the pilot's workplace, it must also be as comfortable and safe as possible.

2. This means that the cockpit is very complicated, with every suitable surface used for instruments and controls. Although the cockpit of each aircraft type is different to every other, the general layout is similar, which helps crew adjust quickly when they fly different aircraft types.

**Fig 12-1** Tornado F3 Cockpit



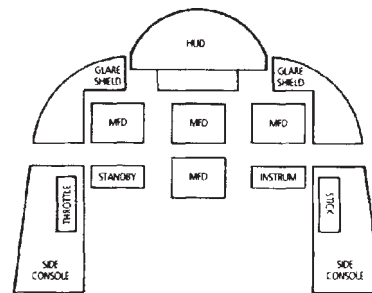
#### INSTRUMENTS

***Layout of cockpit***

3. The greatest problem facing cockpit designers is to decide what information to show and in what way. If too much information is shown, the most important could be difficult to find. If too little is shown, the crew may not have information they need to fly the mission successfully. The instruments which are in constant use are grouped together directly in front of the pilot, on the main instrument panel, with other instruments and controls arranged in groups on the side consoles.

4. Whatever the aircraft, the pilot needs to know its attitude (the aircraft's orientation relative to the horizon), altitude, speed and vertical speed. These instruments are placed centrally, directly in front of the pilot. Apart from some older aircraft, a standard 'T'-shaped configuration is used, as shown in Figure \*\*. The instruments are always placed in the same positions within this shape, although sometimes the functions of two instruments can be combined. The F-15, for example, has a combined air-speed indicator and Mach meter (see paragraph 5).

**Fig 12-2** Military Aircraft Instrumentation



*Schematic of modern military aircraft instrumentation. MFD = multifunction display.*

5. The basic instruments needed to give these read-outs are:

**Attitude Indicator**

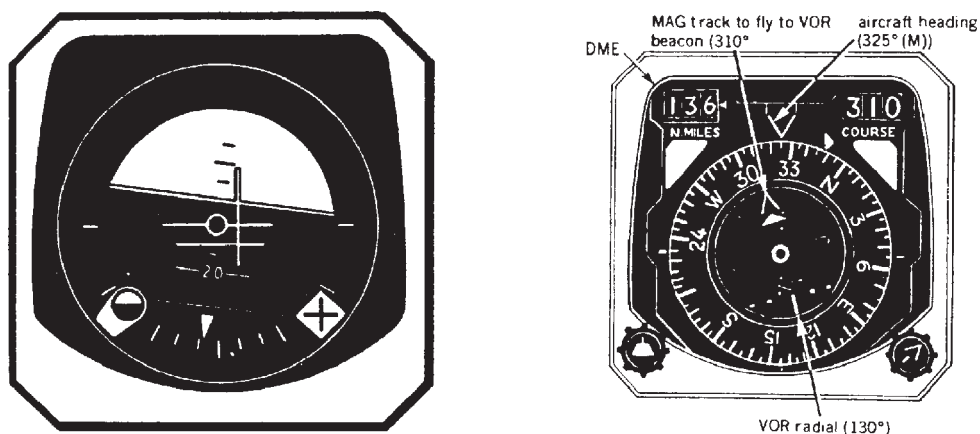
Attitude indicator: this indicates to the pilot the position of the horizon relative to the aircraft, and is also known as the artificial horizon. When visibility is obscured by cloud or at night, it is not possible to see the real horizon. The attitude indicator shows the angle of bank of the aircraft, and also the amount by which the aircraft is flying nose-up or nose-down. It contains a gyroscope, which is rotating at high speed, and because of this will keep a constant position in space. By measuring this position, the instrument can indicate how much the aircraft's attitude has changed. A more modern version is called an attitude director. It does the same job as the artificial horizon, but can also receive inputs from other systems, for example ILS (instrument-landing system), and give directions to the pilot to allow him to fly a particular flight path.

**Horizontal situation indicator**

Horizontal situation indicator: this does a similar job to a compass (in fact, it has a compass built into it), but displays more information as well. It also displays the direction to special radio beacons (or VHF omnidirectional radio range beacons) on the main compass rose scale, and also as a digital readout, and the distance of the aircraft from the beacon (or distance-measuring

equipment). By combining these functions, the aircraft could have a VORDME ILS receiver, which saves weight.

**Fig 12-3** Attitude Director and Horizontal Situation Indicator



#### **Air speed indicator**

Air-speed indicator (ASI): taking its input from the pitot-static probe, usually extending from the nose of the aircraft, this instrument measures the difference in pressure between two parts of the probe (see Figure 86). The pitot part is open directly forwards, and receives ram-air, which is at a higher pressure than the surrounding air because of the forward speed of the aircraft. The static part of the probe is carefully positioned so that the pressure it receives is the same as if the aircraft were not moving at all. By comparing these two pressures inside the ASI, the aircraft speed will be shown. However, it is important to realise that the ASI shows indicated air-speed (); because air is compressible, the readout would need to be corrected at speeds above about half the speed of sound. In fact, IAS is very useful to the pilot, and a calculation to give true air-speed () can be done quite easily when needed, using either a hand computer (the Dalton computer) or the aircraft's on-board computer. Air-speed is always quoted in knots.

#### **Machmeter**

Machmeter: at higher speeds, the pilot needs to have speed information relative to the speed of sound, in other words as a Mach number. So Mach 0.7 is seven tenths of the speed of sound (which is about 760 mph or 1210 km/hr at sea Level), and Mach 2 is twice the speed of sound.

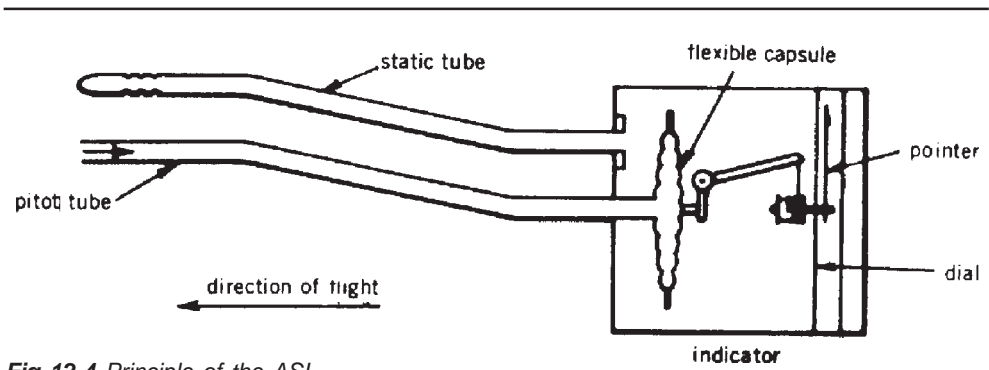


Fig 12-4 Principle of the ASI

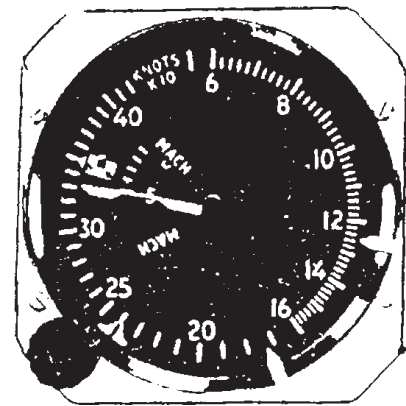


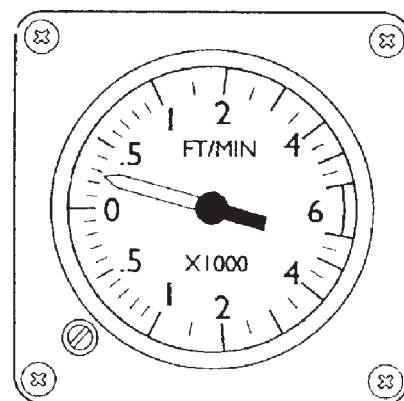
Fig 12-5 Combined Mach-Meter and ASI

**Altimeter**

Altimeter: by comparing the static pressure provided by the pitot-static probe with a reference pressure (for example sea-level pressure) the altimeter indicates the height of the aircraft above the reference height. The scale of the altimeter is always calibrated in feet. The reference pressure is set on the instrument in millibars using a small knob, and appears in a small window on the face of the instrument (Sea level pressure on a 'standard' day is 1013 millibars). In normal cruise, he would use 1013 mb as his reference, giving instrument reading in height above sea level. When approaching an airfield, he would set the local pressure at the airfield ground level, so that his altimeter would read height above ground level. The accuracy of a simple altimeter is not high enough to allow the pilot to use this alone to show his height if he needs to carry out landings in poor visibility. The radio altimeter works by transmitting a radio pulse from the aircraft and measuring the time before its reflection from the ground is received. Although the time to be measured is extremely short, the radio altimeter is highly accurate. Because it works by reflecting radio waves off the ground, it will only give heights above ground level.



*Fig 12-6 Radar Altimeter*



*Fig 12-7 Vertical Speed Indicator*

#### **Vertical Speed Indicator**

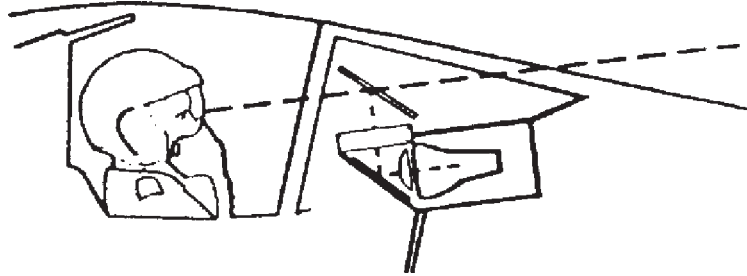
Vertical speed indicator: this instrument shows whether the aircraft is climbing or descending, and how quickly. It has a zero position, showing level flight, at the 'nine o'clock' position, and is calibrated in feet /minute; if the needle is below zero, it shows descent, and above the zero shows climb.

#### **Glass cockpits**

6. In both combat and transport aircraft, new aircraft designs are moving towards the 'glass cockpit' - the use of television-type displays which can be switched to display a wide range of different information, in colour. For combat aircraft in particular, this means that a large number of individual instruments can be replaced by one or two screens. The instruments which are not needed during that part of the flight are not displayed, but the different display modes or settings will show information which is relevant to the kind of mission that is being flown. For instance, a display could show a moving map, so that the aircraft location is kept fixed on the display and the map moves underneath it. When a weapon is selected, the display could then show all the information required to use that system. Modern transport aircraft now use TV-style displays as the main set of instruments, with 'real' instruments used for back-up only. The screens can also show other information, such as engine, navigation and servicing data, for use by the ground maintenance engineers. The glass cockpit system is extremely flexible, and can be set up to give the information in a way which is most easily read and understood by the crew.

---

*Fig 12-8 Head-up Display*



---

### HEAD-UP DISPLAY

7. During flight, especially in combat, a pilot needs to spend as little time as possible looking down at the instrument panel, so he can concentrate on what is happening outside, but he still needs the information that the instruments provide. All combat aircraft have a way around this problem -the head-up display (HUD). The HUD is made up of a projection system and a glass reflector, built into the cockpit panel in front of the pilot. The pilot can see through the glass, but it also reflects a 'picture' showing the most important information from the instruments. The HUD will also show information from the computer, such as gun sights, target marking and missile information.

### CONTROLS

8. Aside from the controls required to steer the aircraft in pitch, roll and yaw, many of the other systems need instructions from the pilot. Examples of these are throttles to control engine speed; undercarriage retraction and extension; radio, navigation and avionics systems; weapon aiming and selection; fuel systems; oxygen and cabin conditioning systems; laser rangefinder. Each of these systems must have switches, buttons and indicators to allow their operation. The cockpit is laid out so that those controls which are least important, or are used least often, are tucked away, leaving the most accessible areas for the controls to which the pilot needs quick and easy access. Some controls are combined with others, for instance the control column may carry switches and buttons to operate the radio, guns and weapon release. More switches may be added to the throttle levers, since the pilot wishes to keep his hands on these two controls as much as possible.

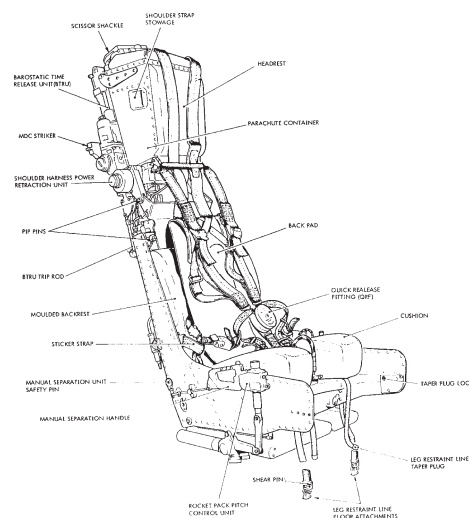
## ESCAPE SYSTEMS

### Ejector seats

9. Because of the speed at which jet aircraft fly, it is not possible for a pilot to jump out of an aircraft in an emergency - the force from the airstream is just too high. Aircrew rightly wish to be as safe as possible, whatever the situation. Almost all combat aircraft now have an ejector seat, often known as a 'bang' seat, which ejects itself and the crew member from the aircraft in an emergency. The seat is operated by pulling a lever or handle, setting into action a chain of events which is automatic from then on. The cockpit canopy is either jettisoned, or shattered by a small explosive cord embedded in it. Then cartridges or rockets are fired, which propel the seat up a rail and clear of the aircraft. A small parachute is deployed, which stabilises the seat, so that it is falling without tumbling. At a safe height, the crew member is ejected from the seat and his personal parachute deployed.

10. The automatic operation of the ejector seat means that an injured pilot can be brought safely to earth even if he is very weak or semi-conscious. If a crew member of a two-seat aircraft is unconscious, and ejection is needed, a commandeject system means that one crew member can operate his partner's ejector seat, saving his life. The seats fitted to all modern aircraft are of the zero-zero type, meaning they can be used at zero speed and zero altitude - when the aircraft is standing still on the runway, for instance if fire breaks out. Ejector seats have saved hundreds of lives since they were first built into aircraft, and no doubt will save hundreds more.

**Fig 12-9 Ejection Seat**



FUTURE DEVELOPMENTS

11. In the future, much of the progress that is made will be in electronic systems to improve the capability and performance of the aircraft. In particular, the glass cockpit concept is likely to become more and more common, with most instruments being moved onto TV-type screens. Looking further ahead, the main instrument panel may become one, single display, like a large computer screen, with every instrument needed being displayed automatically as a colour picture on the screen. The crew will be able to operate every control in the cockpit just by clicking a few buttons on his control column, never needing to take his hands off the control column and throttles.

***Helmet mounted sight***

12. Helmet-mounted sights are already being used, especially in helicopters. The pilot looks through a special visor goggles, which have a weapon sight projected on them. The weapon can be aimed at the target just by the pilot turning his head so that the sight points at the target. This system is likely to be used more and more, because it is fast and easy to operate.

***G-loads***

13. The biggest problem in building an aircraft which can turn very tightly in a dogfight is the ability of the pilot to withstand the g-loads. Tilting the seat back and raising the pilot's legs make him or her much more able to fly in high-g turns without blacking out, but the seat needs to be brought back upright if the crew need to eject. This can be done very quickly, in the time that is needed to jettison the canopy. This illustrates the limiting effects the human body and mind have on future development of aircraft.

## Self Assessment Questions

***Do not mark the paper in any way - write your answers on a separate piece of paper.***

1. What is an attitude indicator?
2. What is an altimeter used for?
3. What is a Vertical Speed Indicator used for?



## INSTRUCTORS GUIDE

### AIRFRAME DESIGN FEATURES

**Page 33.4.1-1 Para 1**

1. The change in aircraft design from biplanes to monolane has been brought about by the ever-increasing need to fly at higher speeds. During the biplane age, only low powered aeroengines were built, and as the biplane could not fly much beyond w50 mph, a light-weight structure, braced externally with struts and wires, was suitable. As the action of the airflow (air loads) on the aircraft was low, doped fabric was satisfactory for covering the wings, fuselage, etc. The internal strength members (spars) of the biplane wing are maintained parallel to one another and are of constant thickness throughout their length. Owing to the external bracing, which takes most of the lift forces, the spars are subject to reduced bending loads and great depth in this is not necessary.

2. The braced monoplane design is used mainly for small high wing aircraft. The bracing struts relieve the spars of much of the life forces and a form of wing construction similar to the biplane is used. To resist the greater bending loads, the spars are deeper than those of the biplane. In this type of design, frontal area and relative drag are much less than the biplane of corresponding span.

3. Most modern aircraft are cantilever monoplanes ie the wings are supported at one end only and decrease in thickness both in plan and elevation towards the wing tip. Air loads increase with the square of the airspeed and at 615 mph are six times as great as at the 250 mph achieved by the fastest biplane. A fabric wing covering is therefore no longer suitable and a heavier and more rigid material, such as plywood or thin metal must be used ie high speed cantilever monoplanes are of stressed skin construction. With the elimination of all external bracing, the use of stressed skin construction, retractable alighting gear and powerful aero-engines, aircraft speeds of over 15000 mph have been achieved which is a great improvement on fabric covered aircraft with a maximum speed of about 250 mph.

**Page 33.4.1-3 Para 3**

4. The fuselage is the body of the aircraft to which the other components such as mainplanes, tail unit and undercarriage are attached. The fuselage contains the pilot's cockpit and may also be fitted with fuel tanks, guns and sometimes the engine, it accommodates the aircraft and may be provided with a bomb bay or space for freight. An external fuel tank, termed the ventral fuel tank, may also be fitted.

**Page 33.4.1-3 Para 4**

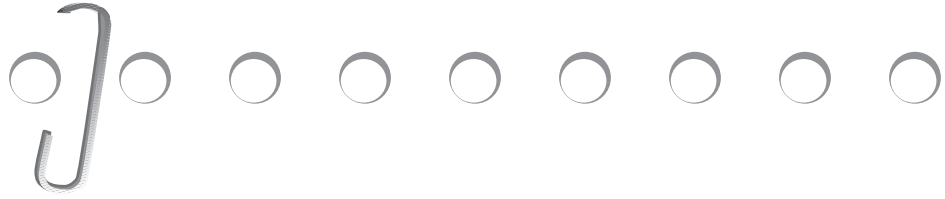
5. The tailplane reduces pitching movement in flight. It is attached to the rear end of the fuselage and may consist of a single plane or separate port and starboard planes. The tailplane may be fixed or suitable mechanism may be incorporated to that its angle to the airflow can be adjusted in flight.

6. The fin, which is the vertical part of the tail, may be built as one with the fuselage or may be a separate component bolted to the fuselage. Some aircraft are fitted with an upper and lower fin. The fin provides directional stability.

**Page 33.4.1-4 Para 5**

7. The undercarriage gear may be fixed or retractable. A retractable undercarriage is divided into two identical units, ie port undercarriage unit and starboard undercarriage unit. Each unit includes a strut-braced oleo leg which, together with the tyre, absorbs the chock of landing. The alighting gear also supports the weight of the aircraft when it is on the ground. Most retracable undercarriage units are hydraulically operated.

## CHAPTER 2

AIRFRAME DESIGN FEATURES - STRUCTURESMaterials**Page 33.4.2-1 Para 1**

1. Wood. Wooden structures have a high strength/weight ratio, are cheap to produce, very easy to make and readily absorbed vibration. But wood does not have uniform qualities, is difficult to obtain in long lengths free from disease and defects, and is difficult to join without reducing its strength. It is also affected by climatic conditions and is inflammable.
  2. Metal. Metal structures are designed to have a high strength/weight ratio, but because they require special tools and highly skilled labour are more expensive to produce than wooden structures. Metal has uniform qualities and strength and absorbs vibration, though it may fail without warning due to fatigue. Although metal will not readily burn, it is subject to corrosion.
  3. Composite. In a composite structure, metal is used for the main structural members for which suitable wood is difficult to obtain, and wood is used for the less important parts. Thus the good qualities of each material are used to the best advantage.
-



### WINGS

**Page 33.4.5-1 Para 1**

1. Wings - Fabric Covered. The shape of a wing is governed by the root end, wing tip, and leading and trailing edge. The space provided for the aileron is termed the aileron gap. The main strength members of the wing are the spars, which extend from the root end to the wing tip and consist of upper and lower booms riveted to a spar web. Attached to the spars and the leading and trailing edges are the ribs, which maintain the correct aerofoil shape, and to which the fabric covering is secured.

2. As the wing is a cantilever structure ie supported at one end only, it has great depth at the root end (where the stresses are greater) and decreases in thickness, both in plan and elevation towards the wing tip. The wing is attached to the fuselage or centre section by engaging the root end fittings of the spars with the attachment points on the fuselage or centre section, and securing the root end bolts.

**Page 33.4.5-2 Para 3**

3. Wings - Stressed Skin. The normal type of stressed skin wing consists of a front spar and a rear spar, together with main ribs, nose ribs, stringers, leading and trailing edges, wing tip and an alclad covering. Internal bracing is not used as the alclad covering gives enough rigidity to the wing.

---

## CHAPTER 6

FUSELAGE AND TAIL UNITS**Page 33.4.6-2 Para 5**

1. Fuselage - Stressed Skin. The normal type of stressed skin fuselage consists of transverse frames or formers, positioned with lengthways members such as longerons or stringers, and the whole covered with a light alloy covering (alclad). The framework of a stressed skin structure is of relatively light weight as the alclad covering provides rigidity and takes the stresses induced by flight. The stressed skin structure also provides a good streamlined shape and fairing is not usually necessary.

**Page 33.4.6-4 Para 8**

2. Tailplane - Stressed Skin. The stressed skin tailplane is of similar construction to the stressed skin wing. To enable the pilot to trim the aircraft in flight, some tailplanes have a tail-adjusting gear. When this device, which can be electrically or mechanically operated, is fitted, one of the tailplane spars is hinged to the fuselage and the other spar is connected to the tail-adjusting gear, operation of the device changes the angle of attack of the tailplane.

---



### ENGINE INSTALLATION

#### Comparison of Piston and Gas turbine Engines

**Page 33.4.7-1 Para 1**

1. When comparing gas turbine (turbo-jet) engines and piston engines for aircraft use, you should consider three factors. The mechanical features, the effect of altitude on each type of engine and the propulsive efficiency. For where the turbo-jet engine produces a thrust (a straight force in pound), the piston engine produces power (foot pounds per minute). To obtain a comparison of engine performance, the method of propulsion (propulsive jet and propeller respectively) should be included in the appraisal.

#### MECHANICAL FEATURES

2. In considering the relative advantages of each power unit it may be said that the piston engine:

- a. Runs efficiently over the full range of engine rpm and can therefore cruise economically at low power and also develop full power irrespective of forward speed.
- b. Has the lower specific fuel consumption.
- c. Has quicker acceleration.
- d. Is cheaper to make. But?
- e. Has the lower power/weight ratio.

3. Conversely, it can be said of the turbo-jet that:

- a. There are no intermittent loads on the bearings and it consequently runs smoothly and without vibration.
- b. It has the higher thrust/weight ratio.
- c. It is mechanically simpler and has fewer moving parts.
- d. Less maintenance is needed.
- e. High-octane fuel is not necessary.
- f. No ignition system is required during engine running. But ?
- g. It is efficient at high engine rpm only.
- h. It has relatively slow acceleration.
- j. It is of high initial cost.
- k. Thrust initially falls with an increase in forward speed although this loss is gradually regained above 350 mph.

## CHAPTER 9

CONTROLSElevators

Page 33.4.9-1 Para 1

1. The elevators are hinged surfaces by means of which the aircraft climbs or dives. They are hinged to the tailplane and moved by operating the control column forwards and backwards; forward movement of the control column lowers the elevators; backward movement raises them.

Rudder

2. The rudder is a hinged surface used in turning the aircraft to port or starboard. The rudder is hinged to the fin and rear end of the fuselage and moved by operating the rudder bar or pedals in the cockpit. Left foot forward, the rudder moves to port; right foot forward the rudder moves to starboard. The tailplane, fin, elevators and rudder are called the 'tail unit'.

Flaps

3. The flaps are hinged surfaces at the rear of the wings, inboard of the ailerons that, when lowered, make the aircraft approach more slowly and steeply. The flaps move by operating a lever or hand-wheel in the cockpit and may be hydraulically, electrically or manually controlled.

---

## Self Assessment Questions - Answer Sheet

### Chapter 1 Page 33.4.1-7

1. c
2. c
3. Support the aircraft on the ground and to absorb landing shocks, allowing the aircraft to land smoothly without bouncing.
4. Using different materials.

### Chapter 2 Page 33.4.2-8

1. d
2. Cantilever structure.
3. Stringers and stiffeners to prevent the skin of the aircraft buckling.

### Chapter 3 Page 33.4.3-7

1. Wing Loading
2. Using smaller wings
3. Aspect Ratio =  $\frac{\text{Span}^2}{\text{Area}}$

### Chapter 4 Page 33.4.4-8

1. Alloys, steels, titanium and plastics
2. By the use of a fatigue meter and comparing with the manufacturer's tests.

### Chapter 5 Page 33.4.5-7

1. The internal structure, such as spars and ribs, and the skin, which can be metal, fabric or composites.
2. They can be machined from a single piece of alloy, called a Billet.

## Self Assessment Questions - Answer Sheet cont...

Chapter 6 Page 33.4.6-6

1. The nose section  
The centre section  
The aft or rear section

Chapter 8 Page 33.4.8-7

1. A type of shock absorber on the undercarriage
2. A sequencer valve
3. Drum and disc brakes

Chapter 9 Page 33.4.9-9

1. Elevators controls pitch  
Rudder control yaw  
Ailerons control roll
2. Manual, power assisted and power operated control systems

Chapter 10 Page 33.4.10-6

1. Instrument Landing System

Chapter 11 Page 33.4.11-13

1. Oil
2. High-pressure air
3. By the use of a humidistat
4. By the use of a constant-speed drive
5. 115 volt, 400 Hz, 3-phase and 28 volt, DC

## Self Assessment Questions - Answer Sheet cont...

Chapter 12      Page 33.4.12-9

1.      An attitude indicator indicates to a pilot the position of the horizon relative to the aircraft, also known as the artificial horizon.
2.      An altimeter is used in an aircraft to indicate the height above the reference height.
3.      A vertical speed indicator is used in an aircraft to show aircraft climbing or descending, and how quickly.